

***Generation Interconnection  
Feasibility Study Report-Web Version***

***For***

***PJM Generation Interconnection Request  
Queue Position Y3-010***

***Millheim - Brush Jct. 46 kV Project***

***August, 2013***

# **Feasibility Study Report**

## **Millheim - Brush Jct. 46 kV Project**

### **Introduction**

This Feasibility Study report provides the documentation of an assessment that has been performed by PJM Interconnection LLC (PJM) and FirstEnergy (FE) in response to a request made by the interconnection customer (IC) for the connection of a 70.0 MW (9.1 MW Capacity) Wind Generation (Y3-010) facility to the West Penn Power Company System at the Millheim - Brush Jct. 46 kV Switching Station. The IC has proposed a commercial operation date of December 2016 for the proposed facility. As per the PJM RTEP study process, the project assessment was accomplished by: 1. Evaluating the reliability impact of the proposed facilities and connection on the interconnected transmission system by the performance of a power flow study; 2. Ensuring compliance with the NERC, ReliabilityFirst, PJM and FE Reliability Standards by identifying the system reinforcements that will need to be installed for an interconnection of the proposed project; 3. Coordinating and cooperating with the PJM staff and IC by participating in project meetings and issuing this report as a part of the RTEP study process; 4. Performing a Steady State, Short-Circuit and Dynamics Study as necessary; 5. Conducting all studies in accordance with the PJM Manuals, the "FE Requirements for Transmission Connected Facilities", and the "FE Study Guide".

### **Connection Facilities**

In compliance with the Regional Transmission Expansion Planning (RTEP) protocol, IC has submitted a "Form of Generation Interconnection Feasibility Study Agreement" to PJM (see Attachment 8) that identifies its plan to install 35 Gamesa 2.0 MW wind turbines connected to a common bus with a total capability of 70.0 MW (9.1 MW capacity.) For purposes of this report, it has been designated as the Millheim - Brush Jct. 46 kV Y3-010 Project (hereinafter, the "Project") to reflect its interconnection voltage and its proximity to the Millheim - Brush Jct. 46 kV line (see Attachment 1.) The IC has requested the study of a Primary Point of Interconnection (POI) for the Project. This report contains detailed connection requirements, direct connection costs and schedule, power flow analysis, short circuit analysis, and a cost and schedule for any associated system reinforcements for the Primary POI.

Primary Point of Interconnection: Millheim - Brush Jct. 46 kV Substation

The Primary POI for the Project will be accomplished by building a new 46 kV ring bus, looping in the Millheim - Brush Jct. 46 kV line and providing a 46 kV meter package. IC will be responsible for acquiring all easements, properties and permits that may be required to construct both the new 46 kV line and the associated attachment facilities. A summary of the Project direct connection facilities that will be required for the Primary POI and their estimated costs are shown on Attachment 3. The one-line for the Primary POI is shown in Attachment 2.

## **PJM Interconnection Study Results**

The following are the results of the analysis performed by PJM engineers with respect to the transmission system impacts.

### **Network Impacts**

The Queue Project #Y3-010 was studied as a 70.0MW (Capacity 9.1MW) injection at the MADISB J 46 kV substation in the PENELEC area. Project #Y3-010 was evaluated for compliance with reliability criteria for summer peak conditions in 2017. Potential network impacts were as follows:

#### **Generator Deliverability**

*(Single or N-1 contingencies for the Capacity portion only of the interconnection)*

None

#### **Light Load Analysis**

Light Load Studies to be conducted during later study phases (applicable to wind, coal, nuclear, and pumped storage projects).

#### **Multiple Facility Contingency**

*(Double Circuit Tower Line, Failed Breaker and Bus Fault contingencies for the full energy output)*

None

#### **Short Circuit**

Refer to “Interconnected Transmission Owner’s Analysis Results” section of this report

#### **Contribution to Previously Identified Overloads**

*(This project contributes to the following contingency overloads, i.e. "Network Impacts", identified for earlier generation or transmission interconnection projects in the PJM Queue)*

1. (PENELEC - PENELEC) The CNYO&G-N.MESHNP 230 kV line (from bus 200924 to bus 200706 ckt 1F) loads from 116.35% to 116.51% (**DC power flow**) of its emergency rating (617 MVA) for the line fault with failed breaker contingency outage of 'C2\_PN115-SB-#19F'. This project contributes approximately 6.25 MW to the thermal violation.

CONTINGENCY 'C2\_PN115-SB-#19F' /\* EAST TOWANDA  
115 KV STUCK CB - CBE (EAST TOWANDA BUS TIE CB)  
DISCONNECT BRANCH FROM BUS 200674 TO BUS 200677 CKT 1

REDUCE BUS 200674 SHUNT BY 100 PERCENT  
DISCONNECT BRANCH FROM BUS 200674 TO BUS 200689 CKT 1  
DISCONNECT BRANCH FROM BUS 200674 TO BUS 200689 CKT 2  
DISCONNECT BRANCH FROM BUS 200676 TO BUS 200674 CKT 1  
DISCONNECT BRANCH FROM BUS 200674 TO BUS 200866 CKT 1  
DISCONNECT BRANCH FROM BUS 200674 TO BUS 200675 CKT 3  
DISCONNECT BRANCH FROM BUS 200674 TO BUS 200675 CKT 4  
END

Please refer to Appendix 1 for a table containing the generators having contribution to this flowgate.

2. (PENELEC - PENELEC) The E.TWANDA-CNYO&G 230 kV line (from bus 200675 to bus 200924 ckt 1F) loads from 131.45% to 131.63% (**DC power flow**) of its emergency rating (549 MVA) for the bus fault outage of 'C1\_PN115-BS-76B'. This project contributes approximately 6.1 MW to the thermal violation.

CONTINGENCY 'C1\_PN115-BS-76B' /\* NORTH  
MESHOPPEN 115 KV MAIN BUS FAULT 2  
DISCONNECT BRANCH FROM BUS 200677 TO BUS 200698 CKT 2  
DISCONNECT BRANCH FROM BUS 200677 TO BUS 200674 CKT 1  
DISCONNECT BRANCH FROM BUS 200677 TO BUS 200687 CKT 2  
DISCONNECT BRANCH FROM BUS 200677 TO BUS 200706 CKT 4  
END

Please refer to Appendix 2 for a table containing the generators having contribution to this flowgate.

3. (PENELEC - PENELEC) The E.TWANDA-CNYO&G 230 kV line (from bus 200675 to bus 200924 ckt 1F) loads from 136.15% to 136.34% (**DC power flow**) of its emergency rating (549 MVA) for the line fault with failed breaker contingency outage of 'C2\_PN115-SB-#19F'. This project contributes approximately 6.25 MW to the thermal violation.

CONTINGENCY 'C2\_PN115-SB-#19F' /\* EAST TOWANDA  
115 KV STUCK CB - CBE (EAST TOWANDA BUS TIE CB)  
DISCONNECT BRANCH FROM BUS 200674 TO BUS 200677 CKT 1  
REDUCE BUS 200674 SHUNT BY 100 PERCENT  
DISCONNECT BRANCH FROM BUS 200674 TO BUS 200689 CKT 1  
DISCONNECT BRANCH FROM BUS 200674 TO BUS 200689 CKT 2  
DISCONNECT BRANCH FROM BUS 200676 TO BUS 200674 CKT 1  
DISCONNECT BRANCH FROM BUS 200674 TO BUS 200866 CKT 1  
DISCONNECT BRANCH FROM BUS 200674 TO BUS 200675 CKT 3  
DISCONNECT BRANCH FROM BUS 200674 TO BUS 200675 CKT 4  
END

Please refer to Appendix 3 for a table containing the generators having contribution to this flowgate.

### **Steady-State Voltage Requirements**

*(Results of the steady-state voltage studies should be inserted here)*

To be determined

### **Stability and Reactive Power Requirement**

*(Results of the dynamic studies should be inserted here)*

To be determined

### **Delivery of Energy Portion of Interconnection Request**

PJM also studied the delivery of the energy portion of this interconnection request. Any problems identified below are likely to result in operational restrictions to the project under study. The developer can proceed with network upgrades to eliminate the operational restriction at their discretion by submitting a Merchant Transmission Interconnection request.

Only the most severely overloaded conditions are listed. There is no guarantee of full delivery of energy for this project by fixing only the conditions listed in this section. With a Transmission Interconnection Request, a subsequent analysis will be performed, which will study all overload conditions associated with the overloaded element(s) identified.

1. (PENELEC - PENELEC) The CNYO&G-N.MESHNP 230 kV line (from bus 200924 to bus 200706 ckt 1F) loads from 123.02% to 123.2% (**DC power flow**) of its normal rating (488 MVA) for non-contingency condition. This project contributes approximately 5.55 MW to the thermal violation.

2. (PENELEC - PENELEC) The E.TWANDA-CNYO&G 230 kV line (from bus 200675 to bus 200924 ckt 1F) loads from 129.06% to 129.25% (**DC power flow**) of its normal rating (488 MVA) for non-contingency condition. This project contributes approximately 5.55 MW to the thermal violation.

## **Interconnected Transmission Owner's Analysis Results**

The following was generated by FirstEnergy the Interconnected Transmission Owner, based upon its analysis, as well as that of PJM, for mitigation of the project's impacts on the transmission and lower voltage system as applicable. It includes the costs and schedules for any system upgrades.

Costs for affected Transmission owners other than FirstEnergy are included and reported in the "New System Reinforcements" and "Contribution to Previously Identified System Reinforcements" sections of the "PJM Interconnection Study Results" above.

### **Power Flow Analysis**

A Power Flow study was conducted to determine the reliability impact of the proposed Project on the FE Transmission System. This included the performance of a contingency analysis to identify any facility overload or voltage condition that violates the FE Planning Criteria. Any such violation that is either directly attributable to this project or for which it will have a shared responsibility is included in this report with a least cost plan identified to mitigate them.

The Power Flow Analysis was performed using a 2017 summer peak load base case provided by the PJM staff. This base case included a detailed representation of the West Penn 46 kV system in the area of the Millheim - Brush Jct. 46kV substation ("Tollhouse" substation). A simulation of all possible contingencies within the NERC and FE Planning Standards that are impacted by the Project was conducted to test for criteria compliance. The direct connection of the Millheim - Brush Jct. 46 kV (Y3-010) Project to the West Penn transmission system was studied at the Primary POI.

The PJM and FE analysis show that the Project does cause additional overloads or criteria violations (see Attachment 4.) As such, new network upgrades are required for the Project.

### **Short Circuit and Dynamics Analysis**

A short circuit analysis has been performed by PJM and the findings were confirmed by FE. The findings show that no circuit breakers are newly over-dutied with the addition of the Project. The study also showed no significant fault current contribution to the breakers which are near the over-duty limit. A dynamics analysis will be performed as part of the Impact study.

### **System Protection Analysis**

Anti-islanding equipment will be installed at Millheim, Pleasant Gap and Centre Hall to permit remote tripping of the generator to prevent an island condition.

### **Metering**

IC will be required to comply with all PJM and FE revenue metering requirements for generation interconnection customers.

### **Compliance Issues**

IC will be responsible for meeting all PJM and FE criteria as defined in the FE Requirements for Distribution Connected Facilities document:

[www.firstenergycorp.com/feconnect](http://www.firstenergycorp.com/feconnect)

[www.pjm.com/planning/design-engineering/to-tech-standards.aspx](http://www.pjm.com/planning/design-engineering/to-tech-standards.aspx)

While the voltage analysis is not performed for the feasibility study, any voltage criteria violations that would require the plant to provide reactive power, that determination of reactive power requirements will be determined in the system impact study, which will include the low voltage ride through analysis.

IC will also be responsible for following the requirements of the “FirstEnergy Wholesale Generation Interconnection (WGI) manual and the “FE Approved Vendors and Contractors” documents which are also located at the above links.

IC must also meet all PJM, ReliabilityFirst and NERC reliability criteria and operating procedures required for standards compliance. For example, the IC will need to properly locate and report the over and under-voltage and over and under-frequency system protection elements for its units as well as the submission of the generator model and protection data required to satisfy the PJM and ReliabilityFirst audits. Failure to comply with these requirements may result in a disconnection of service if the violation is found to compromise the reliability of the FE system.

### **FE Facility Upgrades and Costs**

Results from the PJM and FE Power Flow Analysis (Attachment 4) show that there are no FE criteria violations directly attributable to the capacity of the Project. Therefore in accordance with the RTEP procedures defined in the PJM Open Access Transmission Tariff and PJM Manuals, IC is not responsible for network upgrades (see Attachments 5 and 6.)

Note that all cost estimates contained in this document were produced without a detailed engineering review and are therefore subject to revision. More accurate estimates will be determined as a part of the System Impact Study. IC will be responsible for the actual cost of the direct connection that is implemented. FE herein reserves the right to return to any issues in this document and, upon appropriate justification, request additional monies to complete any reinforcements to the transmission system.

## **Interconnection Customer Requirements**

In addition to the FE facilities, IC will also be responsible for meeting all criteria as specified in the applicable sections of the "FE Requirements for Transmission Connected Facilities" document including:

1. The purchase and installation of a fully rated circuit breaker on the high side of the Y3-010 step-up transformer.
2. The purchase and installation of a lockable load-break switch at the point of interconnection. This switch must be accessible by First Energy.
3. The purchase and installation of the minimum required FE generation interconnection relaying and control facilities. This includes over/under voltage protection, over/under frequency protection, and zero sequence voltage protection relays.
4. The purchase and installation of a 46kV interconnection metering instrument transformer. FE will provide the ratio and accuracy specifications based on the customer load and generation levels.
5. The purchase and installation of a revenue class meter for each unit to measure the power delivered in compliance with the FE standards.
6. The purchase and installation of supervisory control and data acquisition (SCADA) equipment to provide information in a compatible format to the FE Transmission System Control Center. The RTU, the communications channel and all related equipment will be furnished and maintained by IC. The RTU must communicate with the FirstEnergy EMS via DNP 3.0 protocol.
7. The establishment of dedicated communication circuits for SCADA report to the FE Transmission System Control Center.
8. A compliance with the FE and PJM generator power factor and voltage control requirements.
9. The execution of a back-up service agreement to serve the customer load supplied from the Y3-010 46kV interconnection substation when the units are out-of-service. This assumes the intent of IC is to net the generation with the load.
10. The rough grade of the property for the Y3-010 46kV interconnection substation and an access road for the delivery of equipment to this site.

The above requirements are in addition to any metering required by PJM.

## Summary

The Project direct connection will require the facility upgrades defined in Attachment 3. As shown, the total estimated cost of the 46kV ring bus, 2 spans of 46 kV line and meter package is \$6,379,880. This cost includes a CIAC (Contribution in Aid of Construction) Federal Income Tax Gross Up charge of \$1,642,580. This tax may or may not be charged based on whether or not this project meets the eligibility requirements of IRS Notice 88-129. The Project does have any required network upgrades. The total cost of these upgrades is \$12,191,400. This includes a Federal Income Tax Gross Up charge of \$2,782,000.

Based on the scope of the direct connection, it is expected to take a minimum of Thirty-Three months (2.75) years from the signing of an Interconnection Service Agreement/Construction Service Agreement to complete the installation required for the Project. Full payment of the estimated cost of the project will be required upon execution of the Construction Service Agreement (CSA). A true up of the actual cost versus estimated cost of the project will be performed by FE at the end of the project. It also assumes that the IC will provide the property for the Y3-010 46kV interconnection substation and all right-of-way, permits, easements, etc. that will be needed. A further assumption is that there will be no environmental issues with any of the new properties associated with this project, that there will be no delays in acquiring the necessary permits for implementing the defined direct connection and network upgrades, and that PJM will allow all transmission system outages when requested.

**Attachment 1**  
**Millheim - Brush Jct. 46kV (Y3-010) Project**  
**Project Location**

**Attachment 2**  
**Millheim - Brush Jct. 46kV (Y3-010) Project**  
**Primary POI Interconnection Substation Configuration**

**Attachment 3**  
**Millheim - Brush Jct. 46kV (Y3-010) Project**  
**Direct Connection Requirements**

Description	Total with Tax	Tax	Total Cost
<b>Tollhouse SS.</b> Construct 46kV ring bus SS for Y3-010. Grade yard, install ground grid and fence(approximately 120' x 80'). Install 3-3000A, 46kV breakers, 18-46kV hookstick disconnects, 1-1200A, 46kV GOAS, 9-46kV CVT's, 2-1200A 46kV wave traps, 46kV station service, 2-46kV initial bays, bus, structures, foundations. Install metal control building with AC and DC panels, battery & charger, phone, SCADA, control panels and cables, and associated material. Developer to provide property at no cost to FE, to provide fiber between Y3-010 and Tollhouse SS, and comply with FE protection specifications.	4,909,600	1,264,800	3,644,800
<b>Y3-010 Collector SS.</b> Install 46kV metering in developer's collector SS. Developer to provide PT and CT mounting structures and foundations, conduit, and phone line.	200,100	51,600	148,500
<b>Centre Hall SS.</b> Install anti-islanding facilities for Y3-010, including 2-46kV wave traps, 2-46kV CVT's, tuners, and associated facilities. Replace line relays on Brush Jct. 46kV terminal.	557,000	143,500	413,500
<b>Pleasant Gap SS.</b> Install anti-islanding facilities for Y3-010, including 1-46kV wave trap, 1-46kV CVT, tuner, and associated facilities.	243,700	62,800	180,900
<b>Shingletown SS.</b> Install anti-islanding facilities for Y3-010, including 1-46kV wave trap, 1-46kV CVT, tuner, and associated facilities.	243,700	62,800	180,900
Engineering Oversight and Commissioning	186,900	48,200	138,700
Construction of 2 spans of 46 kV and install 2 poles with 12kV underbuild	38,880	8,880	30,000
<b>TOTAL</b>	<b>6,379,880</b>	<b>1,642,580</b>	<b>4,737,300</b>

## Attachment 4 Contingency Analysis

<i>Overloaded Element</i>	<i>Contingency Description</i>	<i>Rating</i>	<i>% Loading</i>	<i>Comments/Reinforcements</i>
Canyon - North Meshoppen 230kV Line	East Towanda Stuck 115kV Bus Tie Breaker	666	107.98	Reconductor line with high temperature conductor. Upgrade terminal equipment at Canyon.
East Towanda - Canyon 230kV Line	North Meshoppen #2 115kV Bus Fault	554	130.49	Reconductor line with high temperature conductor. Upgrade terminal equipment.
East Towanda - Canyon 230kV Line	East Towanda Stuck 115kV Bus Tie Breaker	554	135.15	Reconductor line with high temperature conductor. Upgrade terminal equipment.

Note: Values in red have been updated using to the revised line ratings.

**Attachment 5**  
**Millheim - Brush Jct. 46kV (Y3-010) Project**  
**FE Network Facility Reinforcement Conceptual Costs Estimates**

Description	Total with Tax	Tax	Total Cost
<b>East Towanda SS.</b> Replace substation conductor and relaying on 230kV Canyon line.	194,900	45,200	149,700
<b>Canyon SS.</b> Replace 1200A disconnect switch on 230kV East Towanda Line with 2000A unit.	100,100	23,200	76,900
<b>Canyon-East Towanda 230kV, Reconductor 12.3 Miles w/ 1033 kcmil ACSS.</b> Reconductor the 12.3 mile Canyon-East Towanda 230kV line with 1033 kcmil ACSS, replacing the existing 1033 kcmil ACSR conductor.	11,896,400	2,713,600	9,182,800
<b>Totals</b>	<b>12,191,400</b>	<b>2,782,000</b>	<b>9,409,400</b>

**Attachment 6**  
**Millheim - Brush Jct. 46kV (Y3-010) Project**  
**FE Network Facility Reinforcement Conceptual One Line**  
**Diagrams**

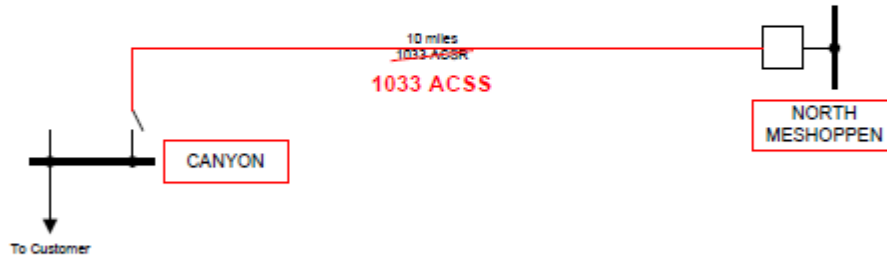

Reconductor 10 miles of 1033 ACSR with 1033 ACSS high temperature conductor.

**Attachment 6**  
**Millheim - Brush Jct. 46kV (Y3-010) Project**  
**FE Network Facility Reinforcement Conceptual One Line**  
**Diagrams**

Continued

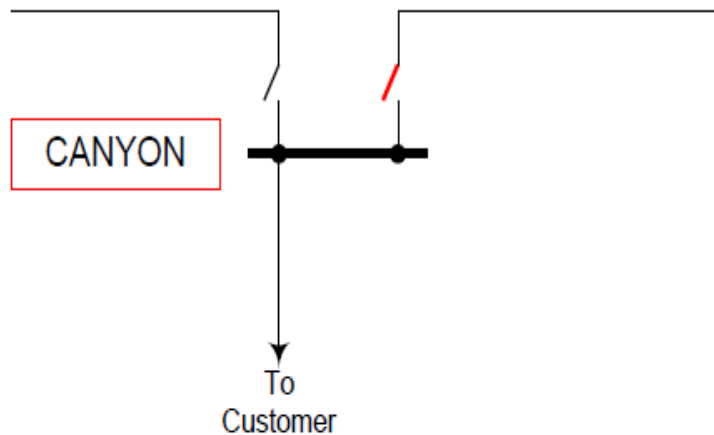

At Canyon, replace the North Meshoppen  
230kV switch with a 2000 A unit.

## **Appendices**

The following appendices contain additional information about each flowgate presented in the body of the report. For each appendix, a description of the flowgate and its contingency was included for convenience. However, the intent of the appendix section is to provide more information on which projects/generators have contributions to the flowgate in question. Although this information is not used "as is" for cost allocation purposes, it can be used to gauge other generators impact.

It should be noted the generator contributions presented in the appendices sections are full contributions, whereas in the body of the report, those contributions take into consideration the commercial probability of each project.

## Appendix 1

(PENELEC - PENELEC) The CNYO&G-N.MESH PN 230 kV line (from bus 200924 to bus 200706 ckt 1F) loads from 116.35% to 116.51% (**DC power flow**) of its emergency rating (617 MVA) for the line fault with failed breaker contingency outage of 'C2\_PN115-SB-#19F'. This project contributes approximately 6.25 MW to the thermal violation.

CONTINGENCY 'C2\_PN115-SB-#19F' /\* EAST TOWANDA  
 115 KV STUCK CB - CBE (EAST TOWANDA BUS TIE CB)  
 DISCONNECT BRANCH FROM BUS 200674 TO BUS 200677 CKT 1  
 REDUCE BUS 200674 SHUNT BY 100 PERCENT  
 DISCONNECT BRANCH FROM BUS 200674 TO BUS 200689 CKT 1  
 DISCONNECT BRANCH FROM BUS 200674 TO BUS 200689 CKT 2  
 DISCONNECT BRANCH FROM BUS 200676 TO BUS 200674 CKT 1  
 DISCONNECT BRANCH FROM BUS 200674 TO BUS 200866 CKT 1  
 DISCONNECT BRANCH FROM BUS 200674 TO BUS 200675 CKT 3  
 DISCONNECT BRANCH FROM BUS 200674 TO BUS 200675 CKT 4  
 END

Bus Number	Bus Name	Full Contribution
200887	ARMNA MT P47	0.15
203261	BLOSSBCT	0.2
200857	LAURHILL	18.06
293270	N-036 C	1.39
293271	N-036 E	5.57
200888	P-047 E	13.24
200649	PENNTECH	0.2
290086	Q-036 E	3.54
296914	R-092 C	1.39
296915	R-092 E	5.57
884780	S-058 C	9.42
884781	S-058 E	31.07
200715	SHAWVL 1	12.83
200722	SHAWVL 2	13.05
200665	SHAWVL 3	19.64
200666	SHAWVL 4	19.44
292391	T-121C	1.8
292392	T-121E	7.2
292984	U2-055C	1.22
292985	U2-055E	8.24
297050	V2-019 E	< 0.01
901902	W1-111 E	1.18
903651	W3-099 C OP1	1.07

903652	W3-099 E OP1	7.17
907481	X1-109	361.97
900404	X3-028 C	19.57
900405	X3-028 E	26.1
X3-050	X3-050	18.93
913401	Y1-012	0.04
913131	Y1-032 C	1.68
913132	Y1-032 E	11.23
Y2-044	Y2-044	30.65
914131	Y2-055	4.69
Y2-068	Y2-068	48.39
915011	Y3-010 C	0.81
915012	Y3-010 E	5.44

## Appendix 2

(PENELEC - PENELEC) The E.TWANDA-CNYO&G 230 kV line (from bus 200675 to bus 200924 ckt 1F) loads from 131.45% to 131.63% (**DC power flow**) of its emergency rating (549 MVA) for the bus fault outage of 'C1\_PN115-BS-76B'. This project contributes approximately 6.1 MW to the thermal violation.

CONTINGENCY 'C1\_PN115-BS-76B'

/\* NORTH

MESHOPPEN 115 KV MAIN BUS FAULT 2

DISCONNECT BRANCH FROM BUS 200677 TO BUS 200698 CKT 2

DISCONNECT BRANCH FROM BUS 200677 TO BUS 200674 CKT 1

DISCONNECT BRANCH FROM BUS 200677 TO BUS 200687 CKT 2

DISCONNECT BRANCH FROM BUS 200677 TO BUS 200706 CKT 4

END

Bus Number	Bus Name	Full Contribution
200887	ARMNA MT P47	0.24
203261	BLOSSBCT	0.23
200857	LAURHILL	16.94
203283	MANOR	0.02
293270	N-036 C	1.77
293271	N-036 E	7.1
200888	P-047 E	21.26
200649	PENNTECH	0.2
290086	Q-036 E	3.59
290113	Q-063 C	0.07
296914	R-092 C	1.41
296915	R-092 E	5.63
884780	S-058 C	10.3
884781	S-058 E	33.95
291011	S-103	0.26
200642	SENECA#1	0.95
200643	SENECA#2	0.88
200644	SENECA#3	0.14
200715	SHAWVL 1	12.69
200722	SHAWVL 2	12.92
200665	SHAWVL 3	19.3
200666	SHAWVL 4	19.12
292391	T-121C	2.19
292392	T-121E	8.75
292984	U2-055C	1.19
292985	U2-055E	8.03
297050	V2-019 E	< 0.01

293416	V3-042C	0.79
293417	V3-042E	5.3
901902	W1-111 E	1.29
903651	W3-099 C OP1	1.19
903652	W3-099 E OP1	7.99
907481	X1-109	330.65
900404	X3-028 C	21.37
900405	X3-028 E	28.5
X3-050	X3-050	21.85
913401	Y1-012	0.05
913131	Y1-032 C	2.1
913132	Y1-032 E	14.03
913191	Y1-047 OP1	1.09
Y2-044	Y2-044	35.38
914131	Y2-055	5.13
914151	Y2-060	0.25
Y2-068	Y2-068	52.85
915011	Y3-010 C	0.79
915012	Y3-010 E	5.31

### Appendix 3

(PENELEC - PENELEC) The E.TWANDA-CNYO&G 230 kV line (from bus 200675 to bus 200924 ckt 1F) loads from 136.15% to 136.34% (**DC power flow**) of its emergency rating (549 MVA) for the line fault with failed breaker contingency outage of 'C2\_PN115-SB-#19F'. This project contributes approximately 6.25 MW to the thermal violation.

CONTINGENCY 'C2\_PN115-SB-#19F' /\* EAST TOWANDA  
 115 KV STUCK CB - CBE (EAST TOWANDA BUS TIE CB)  
 DISCONNECT BRANCH FROM BUS 200674 TO BUS 200677 CKT 1  
 REDUCE BUS 200674 SHUNT BY 100 PERCENT  
 DISCONNECT BRANCH FROM BUS 200674 TO BUS 200689 CKT 1  
 DISCONNECT BRANCH FROM BUS 200674 TO BUS 200689 CKT 2  
 DISCONNECT BRANCH FROM BUS 200676 TO BUS 200674 CKT 1  
 DISCONNECT BRANCH FROM BUS 200674 TO BUS 200866 CKT 1  
 DISCONNECT BRANCH FROM BUS 200674 TO BUS 200675 CKT 3  
 DISCONNECT BRANCH FROM BUS 200674 TO BUS 200675 CKT 4  
 END

Bus Number	Bus Name	Full Contribution
200887	ARMNA MT P47	0.15
203261	BLOSSBCT	0.2
200857	LAURHILL	18.06
293270	N-036 C	1.39
293271	N-036 E	5.57
200888	P-047 E	13.24
200649	PENNTECH	0.2
290086	Q-036 E	3.54
296914	R-092 C	1.39
296915	R-092 E	5.57
884780	S-058 C	9.42
884781	S-058 E	31.07
200715	SHAWVL 1	12.83
200722	SHAWVL 2	13.05
200665	SHAWVL 3	19.64
200666	SHAWVL 4	19.44
292391	T-121C	1.8
292392	T-121E	7.2
292984	U2-055C	1.22
292985	U2-055E	8.24
297050	V2-019 E	< 0.01
901902	W1-111 E	1.18
903651	W3-099 C OP1	1.07

903652	W3-099 E OP1	7.17
907481	X1-109	361.97
900404	X3-028 C	19.57
900405	X3-028 E	26.1
X3-050	X3-050	18.93
913401	Y1-012	0.04
913131	Y1-032 C	1.68
913132	Y1-032 E	11.23
Y2-044	Y2-044	30.65
914131	Y2-055	4.69
Y2-068	Y2-068	48.39
915011	Y3-010 C	0.81
915012	Y3-010 E	5.44