

***PJM Generator Interconnection Request
Queue Y3-024
Bluff Point (Jay County Landfill) 12 kV
Feasibility/Impact Study Report***

November 2013

Y3-024 Bluff Point (Jay County Landfill) 12 kV **Feasibility/Impact Study**

General

Wabash Valley Power Association, Inc. proposes to bring their existing landfill gas plant out from behind the meter. The plant is located on the Jay County Landfill in Portland Indiana (see Figure 1). This is an existing generator facility operating as a Behind-the-Meter facility under Wabash Valley Power Association's account. The capacity and energy is currently netted from Wabash Valley's PLC and hourly energy.

The facility was in-service April 13, 2005. Due to wholesale load switching beginning June 1, 2015 Wabash Valley will not have any load to net the resource against so Wabash Valley would like to convert the facility from Behind-the-Meter to a Generator for capacity and energy settlement purposes. The facility is located on the 12 kV distribution system of AEP. The facility consists of six (4) 0.8 MW Caterpillar 3516 Engines, and is located on the 12 kV distribution system of AEP. The planned in service date is June 1, 2015.



Figure 1 – Jay County Landfill located in Portland, IN

Direct Connection

This is an existing facility. The facility is already connected to the AEP 12 kV system as shown in Figure 2.

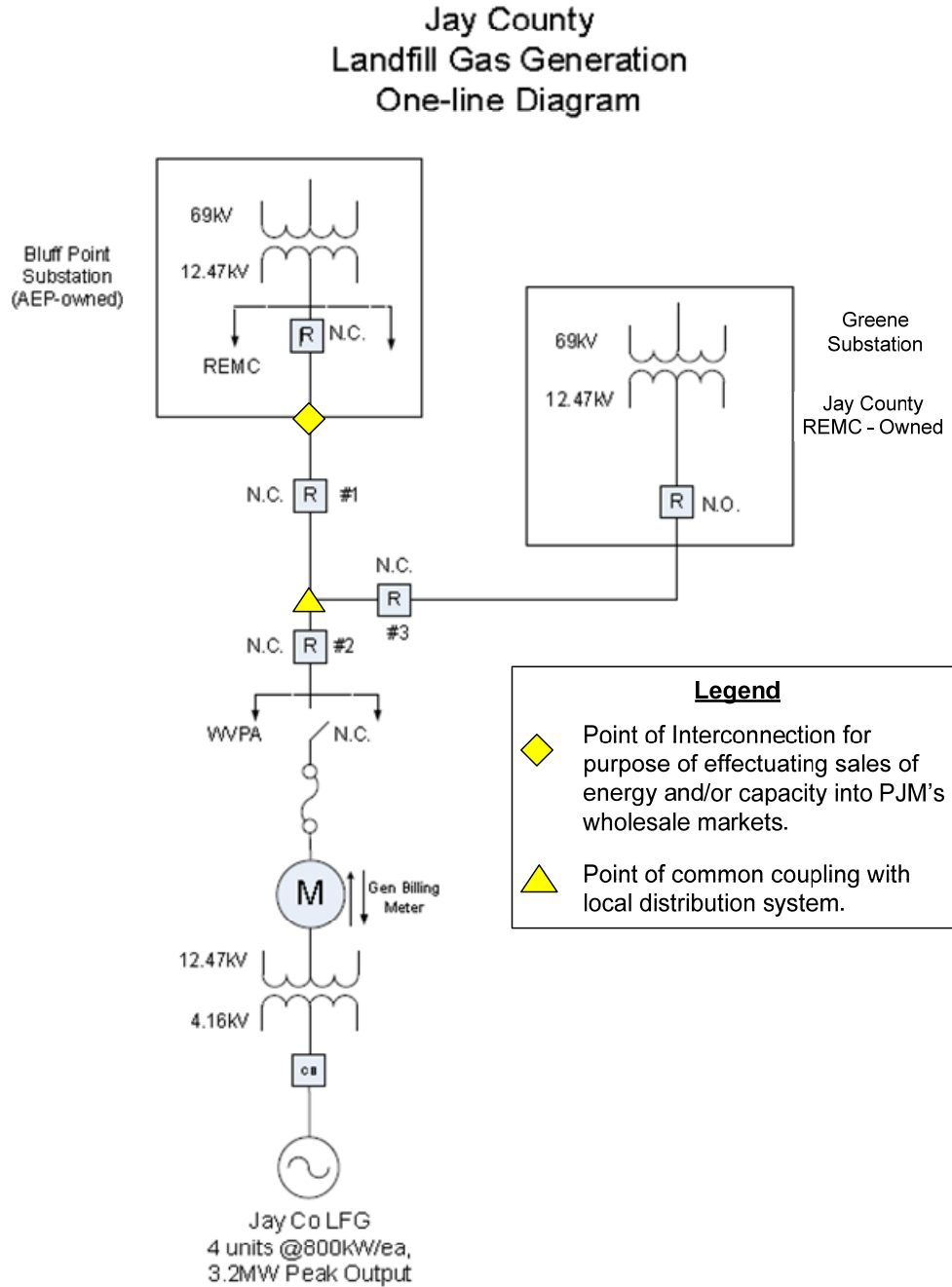

Figure 2

Network Impacts

The Queue Project #Y3-024 was studied as a 3.2 MW (Capacity 3.2 MW) injection at the AEP's Bluff Point 12 kV substation. Project #Y3-024 was evaluated for compliance with reliability criteria for summer peak conditions in 2017. Potential network impacts were as follows:

Generator Deliverability

(Single or N-1 contingencies for the Capacity portion only of the interconnection)

None

Light Load Analysis

Light Load Studies to be conducted during later study phases (applicable to wind, coal, nuclear, and pumped storage projects).

Not required

Multiple Facility Contingency

(Double Circuit Tower Line, Failed Breaker and Bus Fault contingencies for the full energy output)

None

Short Circuit

(Summary form of Cost allocation for breakers will be inserted here if any)

Not required

Contribution to Previously Identified Overloads

(This project contributes to the following contingency overloads, i.e. "Network Impacts", identified for earlier generation or transmission interconnection projects in the PJM Queue)

None

Steady-State Voltage Requirements

(Results of the steady-state voltage studies should be inserted here)

No problems identified

Stability and Reactive Power Requirement

(Results of the dynamic studies should be inserted here)

Not Required

New System Reinforcements

(Upgrades required to mitigate reliability criteria violations, i.e. Network Impacts, initially caused by the addition of this project generation)

None

Contribution to Previously Identified System Reinforcements

*(Overloads initially caused by prior Queue positions with additional contribution to overloading by this project. This project may have a % allocation cost responsibility which will be calculated and reported for the Impact Study)
(Summary form of Cost allocation for transmission lines and transformers will be inserted here if any)*

None

Delivery of Energy Portion of Interconnection Request

PJM also studied the delivery of the energy portion of this interconnection request. Any problems identified below are likely to result in operational restrictions to the project under study. The developer can proceed with network upgrades to eliminate the operational restriction at their discretion by submitting a Merchant Transmission Interconnection request.

Only the most severely overloaded conditions are listed. There is no guarantee of full delivery of energy for this project by fixing only the conditions listed in this section. With a Transmission Interconnection Request, a subsequent analysis will be performed, which will study all overload conditions associated with the overloaded element(s) identified.

None