

***PJM Generator Interconnection Request
Queue Y3-027
Camden (Cinnaminson Solar) 26 kV
Feasibility/Impact Study Report***

September 2013
(Schedule Revised 11/22/13)

Y3-027 Camden (Cinnaminson Solar) 26 kV Impact Study

General

L&D Solar LLC has proposed installing a 6.00 MW solar project located at 1017 Union Landing Rd. Cinnaminson, NJ. The capacity evaluation is based upon 2.28 MW. The original commercial operation date was June 1, 2014, but may need to be amended based on the date the Interconnection agreement is executed, and the availability of long lead time equipment.

The intent of the Feasibility/Impact study is to determine system reinforcements and associated costs and construction time estimates required to facilitate the addition of the new generating plant to the transmission system. The reinforcements include the direct connection of the generator to the system and any network upgrades necessary to maintain the reliability of the transmission system.

Direct Connection

The following is an estimate for the interconnection of 6.00 MW of solar generation by the L&D Solar LLC project in Cinnaminson, New Jersey. As previously specified, the interconnection will consist of a single 26-kV distribution circuit R-486 supplied from the Burlington 26 kV substation. The total interconnection cost of \$345,852 is based on the most efficient possible route to the existing 26 kV Distribution infrastructure and is detailed as follows:

Project Item	26 kV Single Line
	R-486
Inside Plant	
Line Position/Feeder Row	-
Relay Protection	-
Manholes/Conduit	-
Other/Misc.	-
Sub Total	\$0
Outside Plant	
Overhead Line	\$276,752
Underground Line	-
Manholes/Conduit	-
Other/Misc.	-
Sub Total	\$276,752
Metering/Monitoring	
Revenue Metering/Telemetry/SCADA	\$69,100
Feeder Metering	\$0
Other/Misc.	-
Sub Total	\$69,100
Total Cost	\$345,852

This cost is exclusive of work required to be performed by the developer as specified in PSE&G's Information & Requirements for Electric Service Handbook. This work includes, but may not be limited to, the following:

- Developer will adhere to specifications detailed in the PSE&G Information and Requirements for electric service handbook
- Developer is responsible for purchase and installation of all high voltage (13-kV, 26-kV, and 69-kV) service equipment as required
- Developer is responsible for all trenching and the installation of conduits and manholes as normally required and specified by PSE&G
- Developer must obtain all permits and easements required to install the interconnection facilities
- Developer must provide access for the installation, maintenance and operation of all service equipment

It is anticipated that material procurement and construction will require 5-6 months from the date of project approval and authorization.

Project Schedule

December 19, 2013

Wholesale Market Participation Agreement (WMPA) and PSE&G Interconnection Agreement (IA) are fully executed and authorization is received to proceed with construction

August 19, 2014

Long lead time construction material is placed on order

November 3, 2014

Developer submits preliminary site plan, 26-kV switchgear one-line diagram and equipment specifications for approval

November 21, 2014

PSE&G provides comments on project lay-out and design

December 20, 2014

Developer submits final site plan, 26-kV switchgear one-line diagram and equipment specifications for approval

January 7, 2015

PSE&G provides final comments and approval of 26-kV switchgear lay-out and design

Developer begins construction based on approved design

January 21, 2015

PSE&G commences line construction

March 6, 2015

Switchgear inspection and approval by PSE&G

April 25, 2015

Completion of interconnection work and service cut-in

Notes:

- 1) Customer will abide by PSE&G Information and Requirements for electric service hand book
- 2) Customer is responsible to provide trench, conduit and manholes were applicable
- 3) Customer is responsible to provide access and easements
- 4) Customer is responsible to provide permits and associated costs.
- 5) Electric service route was based on most efficient route since no site plans were provided by customer.

Figure #1

PSE&G

Solar Production Sites – 26 kV POI

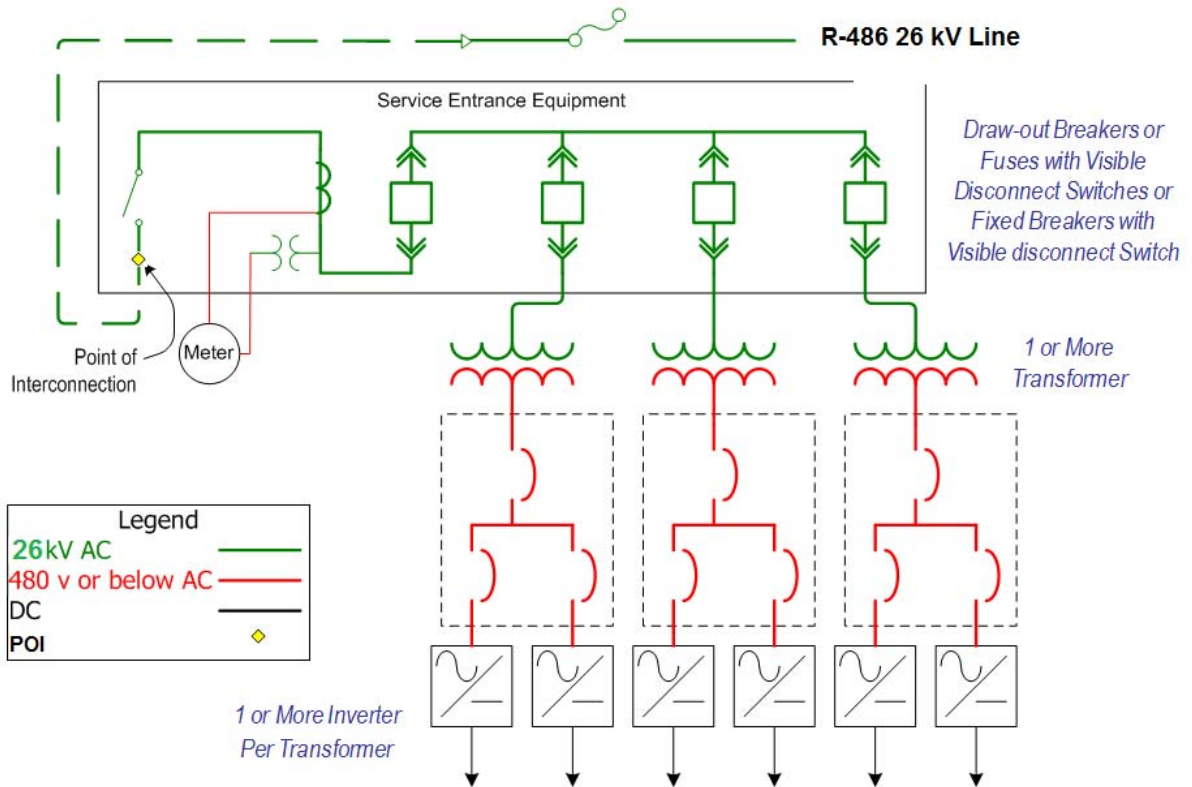

Network Impacts

The Queue Project #Y3-027 was studied as a 6.0MW (Capacity 2.28 MW) injection at the CAMDEN 26 kV substation in the PSEG area. Project #Y3-027 was evaluated for compliance with reliability criteria for summer peak conditions in 2017. Potential network impacts were as follows:

Generator Deliverability

(Single or N-1 contingencies for the Capacity portion only of the interconnection)

None

Light Load Analysis

Light Load Studies to be conducted during later study phases (applicable to wind, coal, nuclear, and pumped storage projects).

Not required

Multiple Facility Contingency

(Double Circuit Tower Line, Failed Breaker and Bus Fault contingencies for the full energy output)

None

Short Circuit

(Summary form of Cost allocation for breakers will be inserted here if any)

Not Required

Contribution to Previously Identified Overloads

(This project contributes to the following contingency overloads, i.e. "Network Impacts", identified for earlier generation or transmission interconnection projects in the PJM Queue)

None

Steady-State Voltage Requirements

(Results of the steady-state voltage studies should be inserted here)

No problems identified

Stability and Reactive Power Requirement

(Results of the dynamic studies should be inserted here)

Not Required

New System Reinforcements

(Upgrades required to mitigate reliability criteria violations, i.e. Network Impacts, initially caused by the addition of this project generation)

None

Contribution to Previously Identified System Reinforcements

*(Overloads initially caused by prior Queue positions with additional contribution to overloading by this project. This project may have a % allocation cost responsibility which will be calculated and reported for the Impact Study)
(Summary form of Cost allocation for transmission lines and transformers will be inserted here if any)*

None

Delivery of Energy Portion of Interconnection Request

PJM also studied the delivery of the energy portion of this interconnection request. Any problems identified below are likely to result in operational restrictions to the project under study. The developer can proceed with network upgrades to eliminate the operational restriction at their discretion by submitting a Merchant Transmission Interconnection request.

Only the most severely overloaded conditions are listed. There is no guarantee of full delivery of energy for this project by fixing only the conditions listed in this section. With a Transmission Interconnection Request, a subsequent analysis will be performed, which will study all overload conditions associated with the overloaded element(s) identified.

None