

***PJM Generation Interconnection Request
Queue Y3-099
Beckjord 2MW - 1
Combined Feasibility/ System Impact Study***

765059v3
December 2013
Updated January 2014

Preface

The intent of this System Impact Study is to determine a plan, with cost and construction time estimates, to connect the subject generation to the PJM network at a location specified by the Interconnection Customer. The Interconnection Customer may request the interconnection of generation as a capacity resource or as an energy-only resource. As a requirement for interconnection, the Interconnection Customer may be responsible for the cost of constructing: (1) Direct Connections, which are new facilities and/or facilities upgrades needed to connect the generator to the PJM network, and (2) Network Upgrades, which are facility additions, or upgrades to existing facilities, that are needed to maintain the reliability of the PJM system.

The PJM Reliability Planning Process utilizes PJM planning criteria, NERC Planning Standards, NERC Regional Council planning criteria, and the individual Transmission Owner FERC filed planning criteria. In all cases, PJM applies the most conservative of all applicable planning criteria when identifying reliability problems and determining the need for system upgrades on the PJM system. The application of the NERC Planning Standards is adapted to the specific needs of the PJM system.

In some instances an interconnection customer may not be responsible for 100% of the identified network upgrade cost because other transmission network uses, e.g. another generation interconnection or merchant transmission upgrade, may also contribute to the need for the same network reinforcement. All facilities required for interconnection of a generation interconnection project must be designed in compliance with the technical specifications (on PJM web site) for the appropriate Transmission Owner.

After the System Impact Study Agreement is executed and prior to execution of the Interconnection Service Agreement, an Interconnection Customer may modify its project to reduce the electrical output (MW) (in the case of a Generation Interconnection Request) of the proposed project by up to the larger of 20 percent of the capability considered in the System Impact Study or 50 MW.

The System Impact Study estimates do not include the feasibility, cost, or time required to obtain property rights and permits for construction of the required facilities. The project developer is responsible for the right of way, real estate, and construction permit issues. For properties currently owned by Transmission Owners, the costs may be included in the study.

General

The Interconnection Customer is proposing a 2MW Energy-only battery to be interconnected to the Duke transmission system and located at the Duke Energy Beckjord Generating Plant in Clermont County, OH. The proposed in-service date for this project is March 31, 2014 and is currently under review.

This Generation Interconnection Feasibility Study provides analysis results to aid the Interconnection Customer in assessing the practicality and cost of incorporating the facility into the PJM system.

Attachment Facilities

The Y3-099 project will interconnect a 2MW Energy-only battery at the existing Duke Energy Beckjord Generating Plant (See **Figure 1** below). The scope of work includes metering, communications, protection and control upgrades to the Beckjord breaker 906 necessary to accommodate connection of the new facilities. The cost estimate of this scope is approximately **\$228,000** (PJM Network Upgrade Number n**4018**) (Note that this figure has not been grossed up for taxes in the event that the reimbursement is considered taxable income. Should this be determined as taxable income, Duke reserves the right to gross up the required reimbursement amount as required).

The Interconnection Customer will be required to comply with all Duke Energy Ohio Requirements for Generation Interconnection Customers. The requirements may be found within the “Requirements for Connection of Facilities to the Duke Energy Midwest Transmission System” and “Interconnection Requirements for Distributed Resources, 10 MVA or Less, Connected in Parallel with the Duke Energy Midwest System” documents. These documents can be requested through the following link:
<http://www.duke-energy.com/ohio/oh-connect-to-the-grid.asp> .

The Interconnection Customer is responsible for constructing all of the Interconnection Customer-owned facilities on the Interconnection Customer’s side of the Point of Interconnection.

Revenue Metering and SCADA Requirements

For PJM: The Interconnection Customer will install equipment necessary to provide Revenue Metering (KWH, KVARH) and real time data (KW, KVAR) for Interconnection Customer’s generating Resource. See PJM Manuals M-01 and M-14D, and PJM Tariff Section 24.1 to 24.2.

For Duke: The Interconnection Customer will be required to comply with all Duke Energy Ohio Revenue Metering Requirements for Generation Interconnection Customers. The Revenue Metering Requirements may be found within the “Duke Energy Midwest Engineering Guide – Interconnection Metering” document.

Network Impacts

The Y3-099 project was studied as a 2.0MW (0.0MW Capacity) injection into the Duke area at the 08BKJ246 138kV substation. Project Y3-099 was evaluated for compliance with reliability criteria for summer peak conditions in 2017.

Potential network impacts were as follows:

Generator Deliverability

(Single or N-1 contingencies for the Capacity portion only of the interconnection)

No violations were found.

Multiple Facility Contingency

(Double Circuit Tower Line contingencies were studied for the full energy output. The contingencies of Line with Failed Breaker and Bus Fault will be performed for the Impact Study.)

No violations were found.

Short Circuit

(Summary of impacted circuit breakers)

Not required.

Contribution to Previously Identified Overloads

(This project contributes to the following contingency overloads, i.e. "Network Impacts", identified for earlier generation or transmission interconnection projects in the PJM Queue)

No violations were found.

Steady-State Voltage Requirements

(Summary of VAR requirements based upon the results of the steady-state voltage studies.)

None.

Light Load Reliability Analysis

(Summary of any reinforcements required to mitigate system reliability issues during light load periods.)

None.

Stability and Reactive Power Requirement

(Summary of VAR requirements based upon the results of the dynamic studies.)

Not required.

New System Reinforcements

(Upgrades required to mitigate reliability criteria violations, I.e. “Network Impacts”, initially caused by the addition of this project’s generation.)

None.

Contribution to Previously Identified System Reinforcements

(Overloads initially caused by prior Queue positions with additional contributions to overloading by this project. This project may have a % allocation cost responsibility which will be calculated and reported for the Impact Study.)

None.

Delivery of Energy Portion of Interconnection Request

PJM also studied the delivery of the energy portion of this interconnection request. Any problems identified below are likely to result in operational restrictions to the project under study. The developer can proceed with network upgrades to eliminate the operational restriction at their discretion by submitting a Merchant Transmission Interconnection request.

Note: Only the most severely overloaded conditions are listed below. There is no guarantee of full delivery of energy for this project by fixing only the conditions listed in this section. With a Transmission Interconnection Request, a subsequent analysis will be performed which shall study all overload conditions associated with the overloaded element(s) identified.

As a result of the aggregate energy resources in the area, no violations were identified.

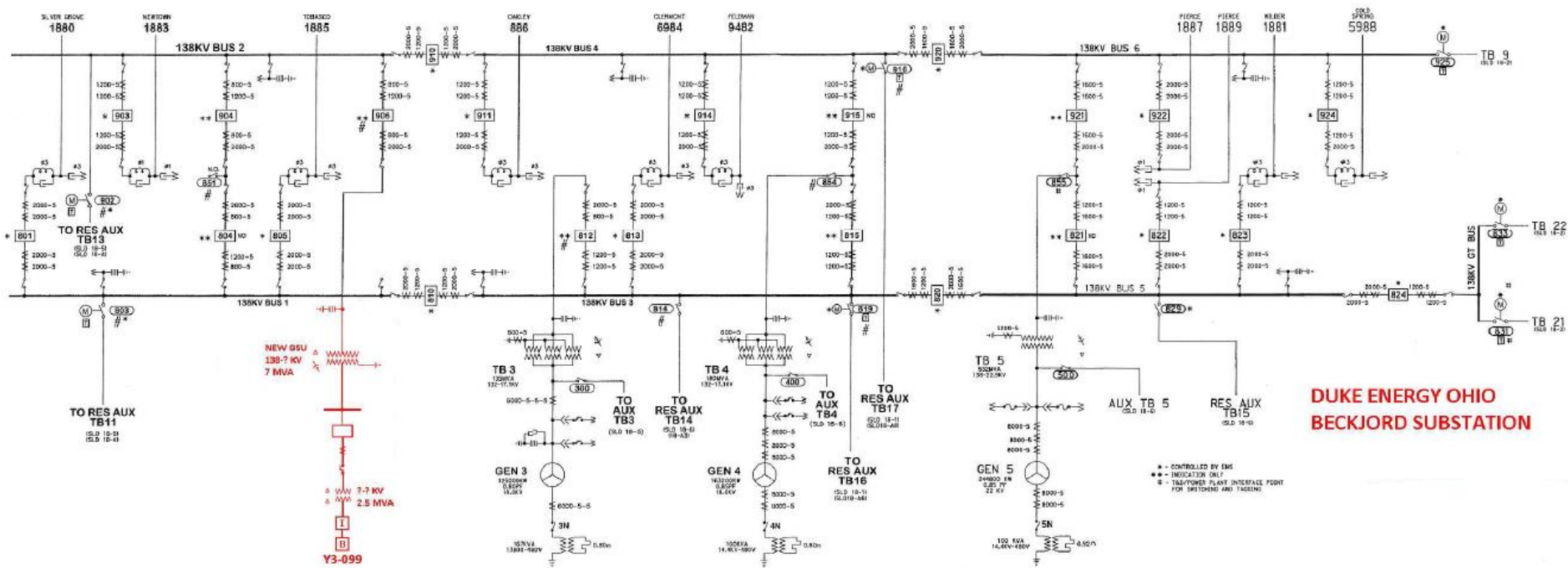

Figure 1. One Line Diagram