

***Generation Interconnection  
Combined Feasibility/Impact Study Report***

***For***

***PJM Generation Interconnection Request  
Queue Position Z2-39***

***Harbor Hydro Holdings, LLC Project***

***March 2015***

# Combined Feasibility/Impact Study Report

## Harbor Hydro Holdings, LLC Project

### Introduction

This combined Feasibility/System Impact Study report provides the documentation of an assessment that has been performed by PJM Interconnection and FirstEnergy (“FE”) in response to a request made by Harbor Hydro Holdings, LLC to increase the capacity of four (4) Hydro generation plants connected to the Rappahannock Electric Cooperative (“REC”) [Warren Hydro] and Shenandoah Valley Electric Cooperative (“SVEC”) [Luray Hydro, Newport Hydro, and Shenandoah Hydroelectric Station] subtransmission systems and the affected Potomac Edison transmission system.

### Connection Facilities

In compliance with the RTEP protocol, Harbor Hydro Holdings, LLC has submitted a "Form of Generation Interconnection Feasibility Study Agreement" to PJM that identifies its plan to increase the combined Capacity (CIR's) for all four aforementioned dam facilities by 3.0 MW. That requested increase amount was subsequently reduced to 2.8 MW. The original Capacity (CIR's) allocated to these four units prior to this queue position was 1.8 MW. After this project's increase of 2.8 MW, the facilities will have, in total, a new Capacity value (CIR's) of 2.6 MW. The maximum facility output will remain unchanged at 4.61 MW.

The individual facilities will have MFO and Capacity values as follows:

Luray	MFO: 1.60 MW	CIR's: 1.60 MW
Newport	MFO: 1.40 MW	CIR's: 1.40 MW
Warren	MFO: 0.75 MW	CIR's: 0.74 MW
Shenandoah	MFO: 0.86 MW	CIR's: 0.86 MW
Total	4.61 MW	4.60 MW

Each dam facility will have an Interconnection Service Agreement prepared granting them these values.

#### *Point of Interconnection (As Studied by FE and PJM):*

- *Luray Hydro (SVEC) – Page 138 kV Substation*
- *Newport Hydro (SVEC) – North Shenandoah 138 kV Substation*
- *Shenandoah Hydroelectric (SVEC) – North Shenandoah 138 kV Substation*
- *Warren Hydro (REC) – Riverton 138 kV Substation*

The Page and Warren County Hydro (Z2-039) Generation Project generators are already connected to the REC and SVEC subtransmission systems which in turn are connected to the FE transmission system at North Shenandoah 138 kV, Page 138 kV, and Riverton 138 kV substations. Therefore, no new direct connection facilities are required to accommodate this request.

## **PJM Transmission Analysis**

### **Network Impacts**

The Queue Project Z2-039 was studied as a 3.0 MW (Capacity 3.0 MW), subsequently reduced to 2.8 MW (2.8 MW Capacity) injection at the Riverton, North Shenandoah and Page 138 kV substations in the APS area. Project Z2-039 was evaluated for compliance with applicable reliability planning criteria (PJM, NERC, NERC Regional Reliability Councils, and Transmission Owners). Project Z2-039 was studied with a commercial probability of 100%. Potential network impacts were as follows:

## **Summer Peak Analysis - 2018**

### **Generator Deliverability**

*(Single or N-1 contingencies for the Capacity portion only of the interconnection)*

None

### **Multiple Facility Contingency**

*(Double Circuit Tower Line, Failed Breaker and Bus Fault contingencies for the full energy output)*

None

### **Contribution to Previously Identified Overloads**

*(This project contributes to the following contingency overloads, i.e. "Network Impacts", identified for earlier generation or transmission interconnection projects in the PJM Queue)*

None

### **Steady-State Voltage Requirements**

*(Results of the steady-state voltage studies should be inserted here)*

Not required

### **Delivery of Energy Portion of Interconnection Request**

PJM also studied the delivery of the energy portion of this interconnection request. Any problems identified below are likely to result in operational restrictions to the project under study. The developer can proceed with network upgrades to eliminate the operational restriction at their discretion by submitting a Merchant Transmission Interconnection request.

Only the most severely overloaded conditions are listed. There is no guarantee of full delivery of energy for this project by fixing only the conditions listed in this section. With a Transmission Interconnection Request, a subsequent analysis will be performed, which will study all overload conditions associated with the overloaded element(s) identified.

Not Applicable

### **Light Load Analysis - 2018**

Not required.

### **System Reinforcements**

#### **New System Reinforcements**

*(Upgrades required to mitigate reliability criteria violations, i.e. Network Impacts, initially caused by the addition of this project generation)*

None

#### **Contribution to Previously Identified System Reinforcements**

*(Overloads initially caused by prior Queue positions with additional contribution to overloading by this project. This project may have a % allocation cost responsibility which will be calculated and reported for the Impact Study)*

*(Summary form of Cost allocation for transmission lines and transformers will be inserted here if any)*

None

#### **Short Circuit**

*(Summary form of Cost allocation for breakers will be inserted here if any)*

Not required

### **Stability and Reactive Power Requirement**

*(Results of the dynamic studies should be inserted here)*

Not required

### **FirstEnergy Analysis Results**

#### **Power Flow Analysis**

A power flow study was conducted to determine the reliability impact of the proposed Page and Warren County Hydro (Z2-039) Generation Project on the FE transmission system. This study was completed using a 2018 summer peak load power flow model that contains a detailed representation of the Potomac Edison transmission network in the area of the proposed Page and Warren County Hydro (Z2-039) Generation Project. The findings and the recommendations from this analysis are based on a contingency review that was performed to identify the facility loadings and/or voltage conditions that violate the ReliabilityFirst, PJM or FE Planning Criteria and are attributable to this project. Note that in accordance with PJM RTEP study procedures, this Page and Warren County Hydro (Z2-039) Generation Project under study and earlier active generation queue projects are considered to be in service. Therefore, all active generation queue projects after the Page and Warren County Hydro (Z2-039) Generation Project are considered not in service.

The results of the FE analysis show that there are no transmission network upgrades required for the Page and Warren County Hydro (Z2-039) Generation Project.

#### **Short Circuit Analysis**

Because Harbor Hydro Holdings, LLC is only proposing an increase to the Capacity of the existing generators and is not changing any installed facilities, no change in the short circuit or dynamic performance of the existing generators is anticipated.

#### **Compliance Issues**

Harbor Hydro Holdings, LLC will be responsible for meeting all FE criteria as defined in the FE “Requirements for Transmission Connected Facilities” document which is found at the following links:

<https://www.firstenergycorp.com/content/fecorp/feconnect/potomacedison/wholesale.html>  
<http://www.pjm.com/planning/design-engineering/to-tech-standards/private-firstenergy.aspx>

Harbor Hydro Holdings, LLC must also meet all PJM, ReliabilityFirst and NERC reliability criteria and operating procedures required for standards compliance. For example, Harbor Hydro Holdings, LLC will need to properly locate and report the over and under-voltage and over and under-frequency system protection elements for its units as well as the submission of the generator model and protection data required to satisfy the PJM and ReliabilityFirst audits. Failure to comply with these requirements may result in a disconnection of service if the violation is found to compromise the reliability of the FE system.

### **Summary**

The results of the FE power flow analysis show that the Page and Warren County Hydro (Z2-039) Generation Project does not attribute to any planning criteria violations. Therefore in accordance with the RTEP procedures defined in the PJM Open Access Transmission Tariff and PJM Manuals, the Harbor Hydro Holdings, LLC is not responsible for any network upgrades.

# Attachment 1

## Single Line Diagram: Luray Dam

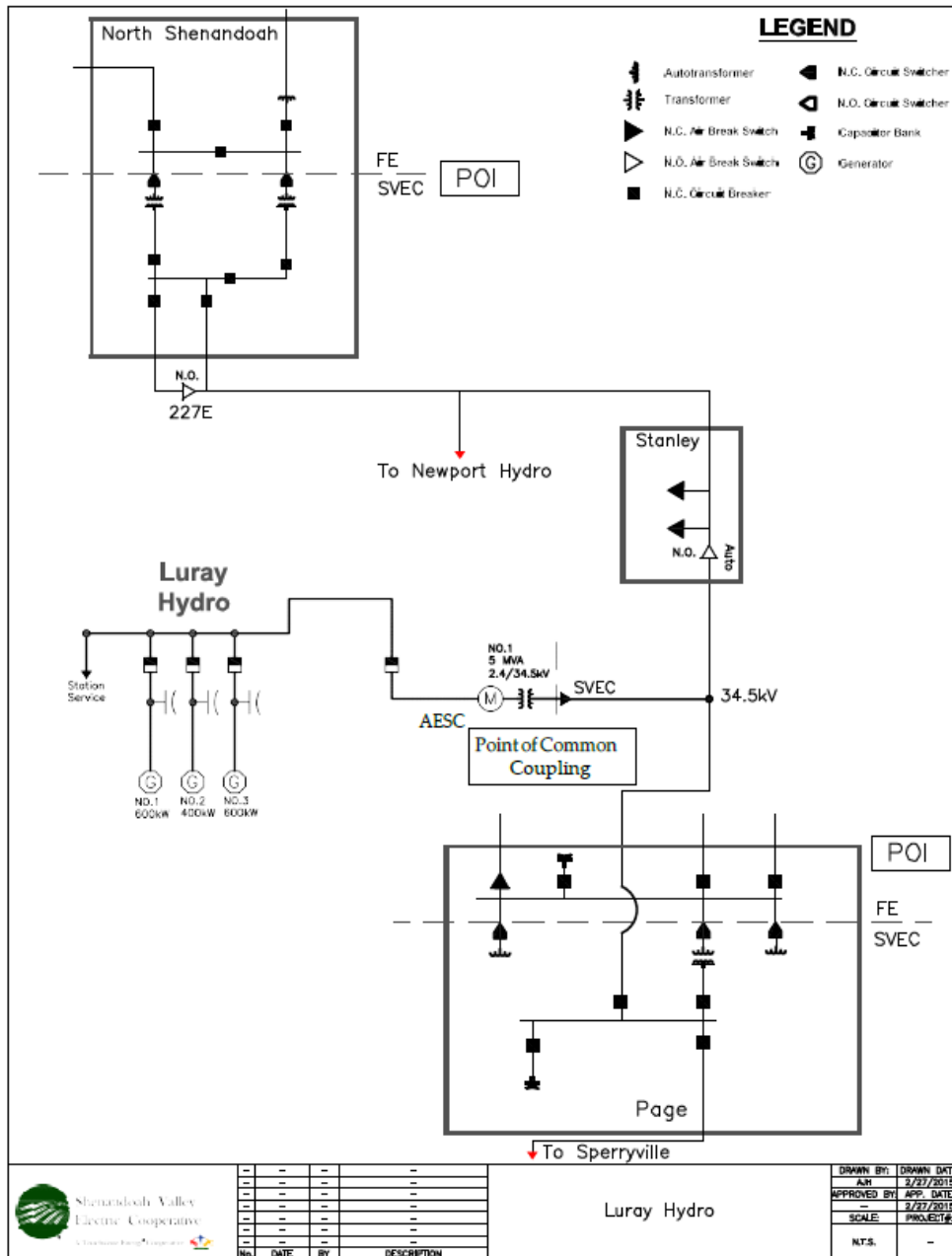

# Attachment 1 (cont'd)

## Single Line Diagram: Newport Dam

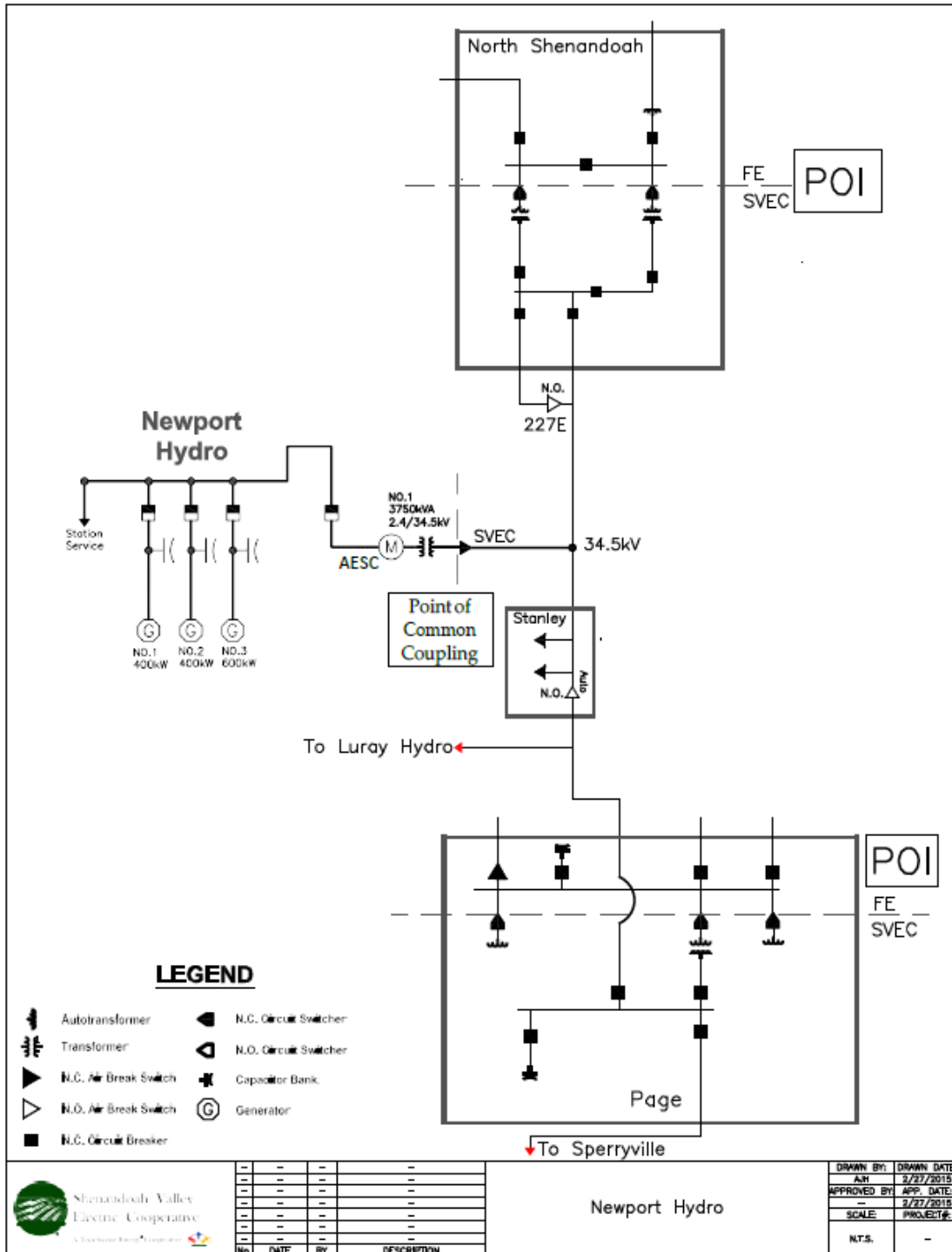

# Attachment 1 (cont'd) Single Line Diagram: Warren Dam

