

***Generation Interconnection  
Combined Feasibility/Impact Study Report***

***For***

***PJM Generation Interconnection Request  
Queue Position Z2-105***

***Bell – Mariana 25kV Project***

***August 2014***

# **Combined Feasibility/Impact Study Report**

## **Bell – Mariana 25kV Project**

### **Introduction**

This Combined Feasibility/Impact Study report This Feasibility Study report provides the documentation of an assessment that has been performed by FirstEnergy (FE) in response to a request made by IMG Development, LLC (the interconnection customer or IC) for the connection of a 19.9 MW Natural Gas Generation (Z2-105) facility on the Bell – Mariana 25 kV Line. The IC has proposed a commercial operation date of January 2016 for the proposed facility. As per the PJM RTEP study process, the project assessment was accomplished by: 1. Evaluating the reliability impact of the proposed facilities and connection on the interconnected transmission system by the performance of a power flow study; 2. Ensuring compliance with the NERC, ReliabilityFirst, PJM and FE Reliability Standards by identifying the system reinforcements that will need to be installed for an interconnection of the proposed project; 3. Coordinating and cooperating with the PJM staff and IMG Development, LLC by participating in project meetings and issuing this report as a part of the RTEP study process; 4. Performing a Steady State, Short-Circuit and Dynamics Study as necessary; 5. Conducting all studies in accordance with the PJM Manuals, the "FE Requirements for Transmission Connected Facilities", and the "FE Study Guide".

### **Connection Facilities**

In compliance with the Regional Transmission Expansion Planning (RTEP) protocol, IMG Development, LLC has submitted a "Form of Generation Interconnection Feasibility Study Agreement" to PJM that identifies its plan to construct a natural gas generation facility connected to a common bus with a total capability of 19.9 MW (19.9 MW capacity.) For purposes of this report, it has been designated as the “Bell – Mariana 25 kV Project” (hereinafter, the “Project”) to reflect its proximity to the Bell – Mariana 25 kV Line (see Attachment 1). This report contains detailed connection requirements, direct connection costs and schedule, power flow analysis, short circuit analysis, and a cost and schedule for any associated system reinforcements.

#### **Primary Point of Interconnection: Bell – Mariana 25 kV Line**

The Point of Interconnection (POI) for the Project will be accomplished by tapping the Bell – Mariana 25 kV line and providing a 25 kV meter package. The IC will be responsible for acquiring all easements, properties and permits that may be required to construct the associated attachment facilities. A summary of the Project direct connection facilities and their estimated costs are shown on Attachment 3. The one-line for the project is shown in Attachment 2.

## **PJM Transmission Analysis**

### **Network Impacts**

The Queue Project Z2-105 was studied as a 19.9 MW (Capacity 19.9 MW) injection at the Bell 25 kV substation in the APS area. Project Z2-105 was evaluated for compliance with applicable reliability planning criteria (PJM, NERC, NERC Regional Reliability Councils, and Transmission Owners). Project Z2-105 was studied with a commercial probability of 100%. Potential network impacts were as follows:

### **Summer Peak Analysis - 2018**

#### **Generator Deliverability**

*(Single or N-1 contingencies for the Capacity portion only of the interconnection)*

None

#### **Multiple Facility Contingency**

*(Double Circuit Tower Line, Failed Breaker and Bus Fault contingencies for the full energy output)*

None

#### **Contribution to Previously Identified Overloads**

*(This project contributes to the following contingency overloads, i.e. "Network Impacts", identified for earlier generation or transmission interconnection projects in the PJM Queue)*

None

#### **Steady-State Voltage Requirements**

*(Results of the steady-state voltage studies should be inserted here)*

To be determined

#### **Delivery of Energy Portion of Interconnection Request**

PJM also studied the delivery of the energy portion of this interconnection request. Any problems identified below are likely to result in operational restrictions to the project under study. The developer can proceed with network upgrades to eliminate the

operational restriction at their discretion by submitting a Merchant Transmission Interconnection request.

Only the most severely overloaded conditions are listed. There is no guarantee of full delivery of energy for this project by fixing only the conditions listed in this section. With a Transmission Interconnection Request, a subsequent analysis will be performed, which will study all overload conditions associated with the overloaded element(s) identified.

Not Applicable

### **Light Load Analysis - 2018**

Not required

### **System Reinforcements**

#### **New System Reinforcements**

*(Upgrades required to mitigate reliability criteria violations, i.e. Network Impacts, initially caused by the addition of this project generation)*

None

#### **Contribution to Previously Identified System Reinforcements**

*(Overloads initially caused by prior Queue positions with additional contribution to overloading by this project. This project may have a % allocation cost responsibility which will be calculated and reported for the Impact Study)*

*(Summary form of Cost allocation for transmission lines and transformers will be inserted here if any)*

None

#### **Short Circuit**

*(Summary form of Cost allocation for breakers will be inserted here if any)*

No problems identified

### **Stability and Reactive Power Requirement**

Not required

## **FirstEnergy Analysis Results**

### **Power Flow Analysis**

A Power Flow study was conducted to determine the reliability impact of the proposed Project on the FE Transmission System. This included the performance of a contingency analysis to identify any facility overload or voltage condition that violates the FE Planning Criteria. Any such violation that is either directly attributable to this project or for which it will have a shared responsibility is included in this report with a least cost plan identified to mitigate them.

The Power Flow Analysis was performed using a 2018 summer peak load base case provided by the PJM staff. This base case included a detailed representation of the West Penn system. A simulation of contingencies within the FE Planning Standards that are impacted by the Project were analyzed to test for criteria compliance. The direct connection of the Bell – Mariana 25 kV (Z2-105) Project to the West Penn transmission system was studied.

### **Short Circuit and Dynamics Analysis**

A short circuit analysis has been performed by PJM and the findings were confirmed by FE. Results show that no circuit breakers are newly over-dutied with the addition of the Project.

### **System Protection Analysis**

An analysis was conducted to assess the impact of the Project on the system protection requirements in the area. Results of this review have identified the following:

Upgraded line relaying is required for direct connection at both Bell and Mariana 25 kV substations.

#### **Bell Substation**

- Install the following line protection equipment:  
1 SEL 421 Relay

#### **Mariana Substation**

- Install the following line protection equipment:  
1 SEL 421 Relay

### **Metering**

IMG Development, LLC will be required to comply with all FE revenue metering requirements for generation interconnection customers. These FE requirements are detailed on Attachment 7 of this report.

### **Compliance Issues**

IMG Development, LLC will be responsible for meeting all FE criteria as defined in the FE Requirements for Transmission Connected Facilities document:

[www.firstenergycorp.com/feconnect](http://www.firstenergycorp.com/feconnect)  
[www.pjm.com/planning/design-engineering/to-tech-standards.aspx](http://www.pjm.com/planning/design-engineering/to-tech-standards.aspx)

IMG Development, LLC must meet all PJM, ReliabilityFirst and NERC reliability criteria and operating procedures. For example, the IC will need to properly locate and report the over and under-voltage and over and under-frequency system protection elements for its units as well as the submission of the generator model and protection data required to satisfy the PJM and ReliabilityFirst audits. Failure to comply with these requirements may result in a disconnection of service if the violation is found to compromise the reliability of the FE system.

### **FE Facility Upgrades and Costs**

Results from the Power Flow Analysis (Attachment 4) show there are FE Transmission Planning Criteria violations directly attributable to the capacity of the Project. Therefore in accordance with the RTEP procedures defined in the PJM Open Access Transmission Tariff and PJM Manuals, the IC is responsible for network upgrades necessary to mitigate the criteria violations. The network upgrade cost and scope of work is summarized in Attachments 5 and 6.

The criteria violation identified is a thermal overload of the Bell-Mariana 25 kV line (loading exceeding 100%). The IC will be responsible for the cost of installing larger wire (reconductoring) on the Bell-Mariana 25 kV line.

Note that all cost estimates contained in this document were produced without a detailed engineering review and are therefore subject to revision. More accurate estimates will be determined as a part of the Facility Study. The IC will be responsible for the actual cost of the direct connection that is implemented. FE herein reserves the right to return to any issues in this document and, upon appropriate justification, request additional monies to complete any reinforcements to the transmission system.

### **IMG Development, LLC Requirements**

In addition to the FE facilities, IMG Development, LLC will also be responsible for meeting all criteria as specified in the applicable sections of the "FE Requirements for Transmission Connected Facilities" document including:

1. The purchase and installation of a fully rated circuit breaker on the high side of the Z2-105 step-up transformer.

2. The purchase and installation of a lockable load-break switch at the point of interconnection. This switch must be accessible by First Energy.
3. The purchase and installation of the minimum required FE generation interconnection relaying and control facilities. This includes over/under voltage protection, over/under frequency protection, and zero sequence voltage protection relays.
4. The purchase and installation of a 25 kV interconnection metering instrument transformer. FE will provide the ratio and accuracy specifications based on the customer load and generation levels.
5. The purchase and installation of a revenue class meter for each unit to measure the power delivered in compliance with the FE standards.
6. The purchase and installation of supervisory control and data acquisition (SCADA) equipment to provide information in a compatible format to the FE Transmission System Control Center. The RTU, the communications channel and all related equipment will be furnished and maintained by IMG Development, LLC. The RTU must communicate with the FirstEnergy EMS via DNP 3.0 protocol.
7. The establishment of dedicated communication circuits for SCADA report to the FE Transmission System Control Center.
8. A compliance with the FE and PJM generator power factor and voltage control requirements.
9. The execution of a back-up service agreement to serve the customer load supplied from the Z2-105 25 kV interconnection substation when the units are out-of-service. This assumes the intent of IMG Development, LLC is to net the generation with the load.
10. The rough grade of the property for the Z2-105 25 kV interconnection substation and an access road for the delivery of equipment to this site.

The above requirements are in addition to any metering required by PJM.

## Summary

The Project direct connection will require the facility upgrades defined in Attachment 3. As shown, the total estimated cost of the direct connection facilities is \$462,200. This cost includes a CIAC (Contribution in Aid of Construction) Federal Income Tax Gross Up charge of \$107,500. This tax may or may not be charged based on whether or not this project meets the eligibility requirements of IRS Notice 88-129. The Project does require network upgrades as defined in Attachment 5. As shown, the total estimated cost for the required network upgrades is \$2,427,600. This cost includes a CIAC (Contribution in Aid of Construction) Federal Income Tax Gross Up charge of \$554,500. This tax may or may not be charged based on whether or not this project meets the eligibility requirements of IRS Notice 88-129.

Based on the scope of the direct connection, it is expected to take a minimum of fourteen months (14) from the signing of an Interconnection Service Agreement/Construction Service Agreement to complete the installation required for the Project. This includes a preliminary payment that compensates FE for the first three months of the engineering design work that is related to the construction of the Z2-105 25 kV interconnection substation. It also assumes that the IC will provide right-of-way, permits, easements, etc. that will be needed. A further assumption is that there will be no environmental issues with any of the new properties associated with this project, that there will be no delays in acquiring the necessary permits for implementing the defined direct connection and network upgrades, and that PJM will allow all transmission system outages when requested.

**Attachment 1**  
**Bell – Mariana 25 kV (Z2-105) Project**  
**Project Location**



# Attachment 2

## Bell – Mariana 25 kV (Z2-105) Project

### Primary POI Interconnection Substation Configuration

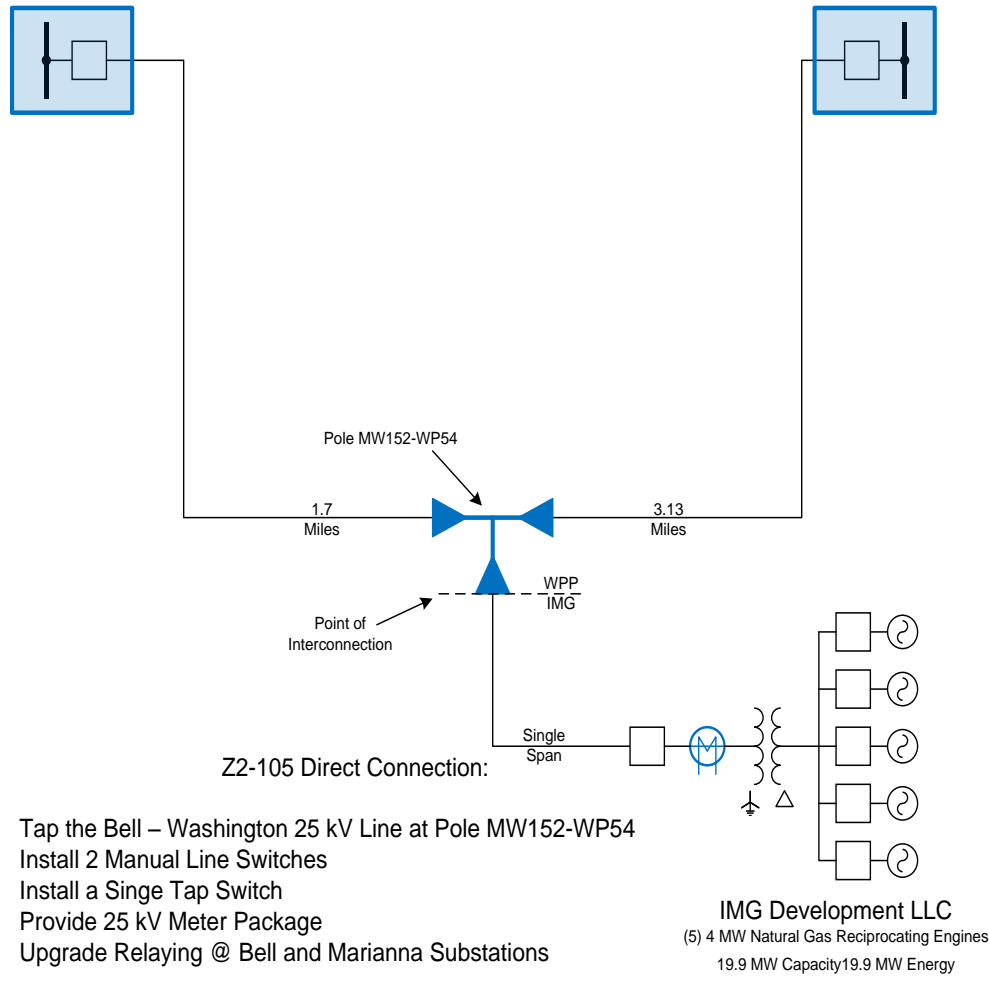

## Attachment 3

# Bell – Marina 25 kV (Z2-105) Project

## Direct Connection Requirements

Number of Months to Complete -- 14 Months.

Estimate No.	Description	Total with Tax	Tax	Total Cost
WP-S-246	<b>Bell SS.</b> Replace the relays on the Marianna 25kV Line.	74,700	18,000	56,700
WP-S-247	<b>Marianna SS.</b> Replace the relays on the Bell 25kV Line.	74,700	18,000	56,700
Region	25kV Line Tap on the <b>Bell - Marianna Line</b>	136,800	31,300	105,500
EOC FE-7 No OTB	Engineering Oversight and Commissioning - FE Construction (No-OTB) - FE-7	176,000	40,200	135,800
<b>Totals</b>		<b>462,200</b>	<b>107,500</b>	<b>354,700</b>

# **Attachment 4**

## **Contingency Analysis**

FE Study Thermal Violations:

Overload: Marianna – Z2-105 Tap 25 kV Line (157% SE Rating 16 MVA)  
Contingency - Loss of Amity – Washington 25 kV

**Attachment 5**  
**Bell – Mariana 25 kV (Z2-105) Project**  
**FE Network Facility Reinforcement Conceptual Costs Estimates**

Description	Total with Tax	Tax	Total Cost
Reconductor Bell - Marianna 25kV line with 556 AAC Conductor for approximately 4.83 miles.	2,427,600	554,500	1,873,100
<b>Totals</b>	<b>2,427,600</b>	<b>554,500</b>	<b>1,873,100</b>

**Attachment 6**  
**Bell – Marianna 15 kV (Z2-105) Project**  
**FE Network Facility Reinforcement Conceptual One Line**  
**Diagrams**

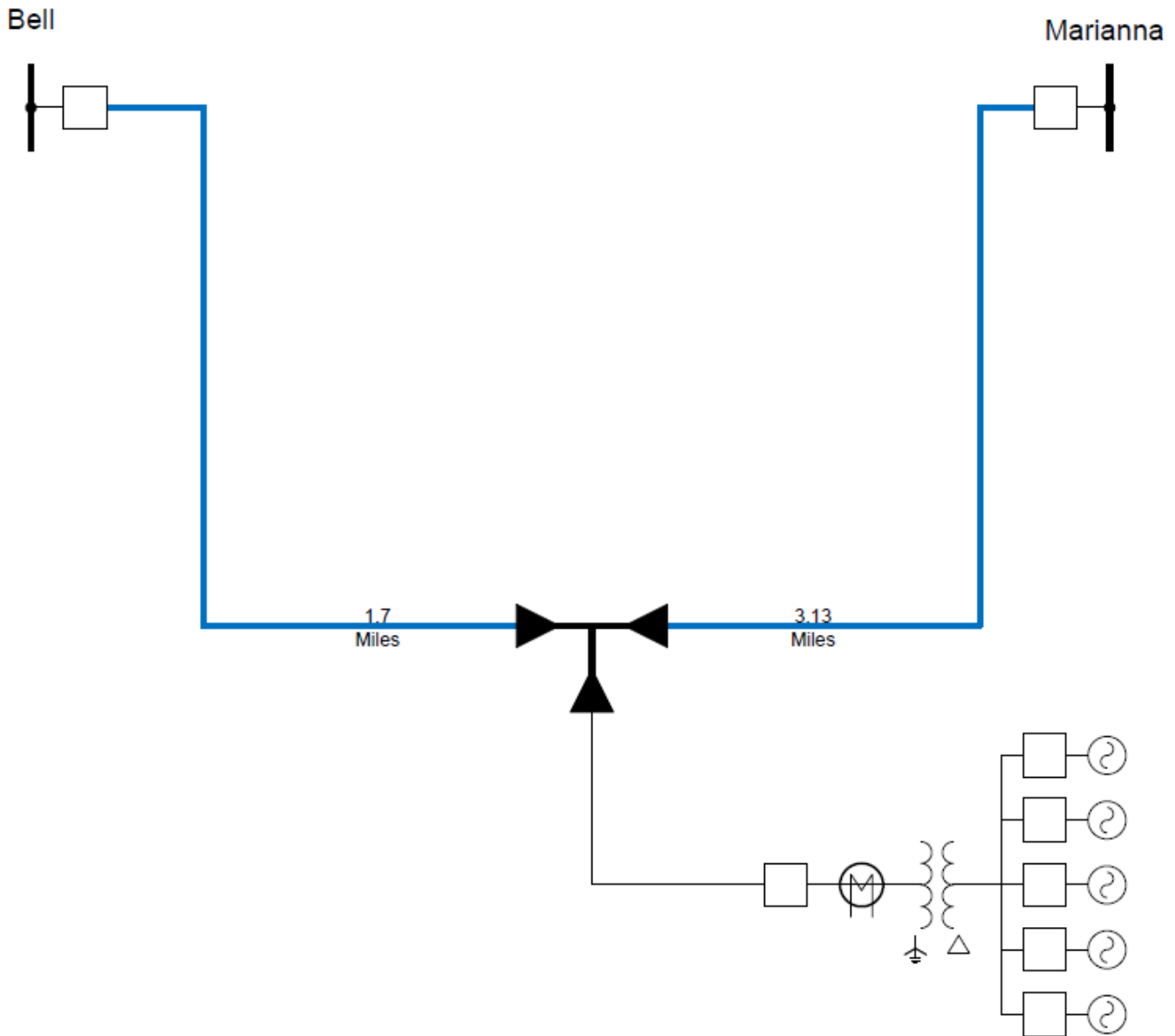

Z2-105/Z2-106 Network Upgrades:

- Reconductor Bell – Marianna 25 kV Line with 556 AAC Conductor (~4.83 Miles)

## **Attachment 7**

# **FE Revenue Metering Requirements**

The FirstEnergy Revenue Metering Requirements may be found in the FirstEnergy Requirements for Transmission Connected Facilities document located at the following links:

[www.firstenergycorp.com/feconnect](http://www.firstenergycorp.com/feconnect)  
[www.pjm.com/planning/design-engineering/to-tech-standards.aspx](http://www.pjm.com/planning/design-engineering/to-tech-standards.aspx)