

FEDERAL ENERGY REGULATORY COMMISSION
WASHINGTON, DC 20426

OFFICE OF ENERGY MARKET REGULATION

PJM Interconnection, L.L.C.
Docket No. ER20-325-000

Issued: 12/27/19

Mark J. Stanisz
PJM Interconnection, L.L.C.
2750 Monroe Blvd.
Audubon, Pennsylvania 19403

Reference: Notice of Cancellation of Service Agreement Nos. 1012 and 944

On November 6, 2019, PJM Interconnection, L.L.C. (PJM) submitted for filing a notice of cancellation for two interconnection service agreements (ISA): Service Agreement No. 1012 among PJM, Mannington Mills, Inc. and Atlantic City Electric Company (Mannington ISA) and Service Agreement No. 944 among PJM, DuPont Textiles and Interiors, Inc., and Delmarva Power and Light Company (DuPont Textiles ISA). PJM states that the Mannington ISA is being cancelled effective June 1, 2019 upon the deactivation date of the generation units under the Mannington ISA. PJM states that the generation units under the Mannington ISA did not receive Capacity Interconnection Rights (CIRs) and did not participate in PJM's wholesale market. PJM states that the DuPont Textiles ISA is being cancelled effective September 30, 2010, one year after the deactivation date of the generation unit under the Dupont Textiles ISA. PJM states that the Dupont Textiles ISA remained effective one year after the generation unit's deactivation date to preserve the unit's CIRs.¹

Pursuant to the authority delegated to the Director, Division of Electric Power Regulation – East, under 18 C.F.R. § 375.307, your submittal is accepted for filing, effective as requested.

The filing was noticed on November 7, 2019, with comments, interventions, and protests due on or before November 27, 2019. Pursuant to Rule 214 (18 C.F.R. §

¹ It appears that contrary to the requirements of section 35.15 of the Commission's regulations (18 C.F.R. § 35.15 (2019)), PJM failed to file the notice of cancellation in a timely manner. PJM is reminded that it must submit required filings on a timely basis or face possible sanctions by the Commission.

Docket No. ER20-325-000

385.214 (2019)), to the extent that any timely filed motions to intervene and any motion to intervene out-of-time were filed before the issuance date of this order, such interventions are granted. Granting late interventions at this stage of the proceeding will not disrupt the proceeding or place additional burdens on existing parties.

This acceptance for filing shall not be construed as constituting approval of the referenced filing or of any rate, charge, classification, or any rule, regulation, or practice affecting such rate or service contained in your filing; nor shall such acceptance be deemed as recognition of any claimed contractual right or obligation associated therewith; and such acceptance is without prejudice to any findings or orders which have been or may hereafter be made by the Commission in any proceeding now pending or hereafter instituted by or against PJM.

This order constitutes final agency action. Requests for rehearing by the Commission may be filed within 30 days of the date of issuance of this order, pursuant to 18 C.F.R. § 385.713.

Issued by: Kurt M. Longo, Director, Division of Electric Power Regulation – East

Document Content(s)

ER20-325-000 Delegated Letter.DOCX.....1-2



PJM Interconnection, L.L.C.
2750 Monroe Boulevard
Audubon, PA 19403

Mark J. Stanisz
Senior Counsel
T: (610) 666-4707 | F: (610) 666-8211
Mark.Stanisz@pjm.com

November 6, 2019

Honorable Kimberly D. Bose, Secretary
Federal Energy Regulatory Commission
888 First Street, N.E., Room 1A
Washington, D.C. 20426-0001

*Re: PJM Interconnection, L.L.C., Docket No. ER20-325-000
Notice of Cancellation of Two Service Agreements*

Dear Secretary Bose:

I. DESCRIPTION OF FILING

PJM Interconnection, L.L.C. (“PJM”) submits this filing to notify the Federal Energy Regulatory Commission (“Commission”) of a notice of cancellation of two interconnection service agreements (“ISAs”).¹ PJM is submitting the notices of cancellation for: (i) Service Agreement No. 1012 among PJM, Mannington Mills, Inc. and Atlantic City Electric Company (“Mannington ISA”); and (ii) Service Agreement No. 944 among PJM, DuPont Textiles and Interiors, Inc., and Delmarva Power and Light Company d/b/a Conectiv Power Delivery (“DuPont Textiles ISA”) (collectively, the “Service Agreements”). Although the generation units deactivated June 1, 2019 and September 30, 2009, respectively, PJM was not advised of the deactivation date associated with the Mannington ISA until October 8, 2019 and the DuPont Textiles ISA until October 17, 2019. PJM has promptly filed this notice of cancellation upon verifying these deactivation dates.

¹ See PJM Open Access Transmission Tariff (“PJM Tariff”), Attachment O (“Form ISA”).

The generation units under the Mannington ISA did not receive Capacity Interconnection Rights (“CIRs”), and did not participate in PJM’s Wholesale Market. Therefore, PJM is requesting the Mannington ISA be cancelled effective June 1, 2019 upon the deactivation date of the Mannington Mills Units 1, 2, and 3.

The generation unit that deactivated under the DuPont Textiles ISA was granted CIRs. Therefore, the DuPont Textiles ISA remained effective one year after the generation unit’s deactivation date to preserve the unit’s CIRs for one additional year after the deactivation date.² PJM is therefore requesting that the DuPont Textiles ISA be cancelled effective September 30, 2010.

II. WAIVER AND EFFECTIVE DATE

PJM respectfully requests a notice of cancellation effective date of: (i) June 1, 2019 for the Mannington ISA, which is the date the unit deactivated because there are no CIRs associated with the Mannington ISA; and (ii) September 30, 2010 for the DuPont Textiles ISA, which is one year from the deactivation date and thus the date the generation unit’s CIRs expired. To the extent necessary, PJM requests a waiver of the Commission’s sixty day (60) notice requirement to permit such effective dates.³ The Parties have no remaining obligations under these Service Agreements.

In the past, the Commission has focused on several factors in evaluating whether sufficient “good cause” exists to grant such waiver requests. The Commission has granted tariff waivers

² See PJM Tariff, Part VI, section 230.3.3.

³ See 18 C.F.R. § 35.15 (2016) (“Section 35.15”) (“[f]or good cause shown, the Commission may by order provide that the notice of cancellation or termination shall be effective as of a date prior to the date of filing or prior to the date the filing would become effective in accordance with these rules.”).

when circumstances arise from an “inadvertent mishap.”⁴ Also, the Commission will consider whether the applicant took steps to correct the problem after discovering the error.⁵

Other factors the Commission has considered include an evaluation of whether the requested relief is intended to address a limited set of circumstances and system reliability was not jeopardized as a result of the applicant’s failure to comply with the tariff requirement at issue.⁶ In sum, the Commission has generally granted such waiver requests where: (1) the underlying error was made in good faith; (2) the waiver was of limited scope; (3) a concrete problem needed to be remedied; and (4) the waiver did not have undesirable consequences, such as harming third parties.⁷

PJM’s waiver request in this instance meets all four factors. First, the underlying issue in this proceeding arises from circumstances over which PJM did not have control. In fact, PJM did not have certainty about the deactivation dates for the generation units until October 2019, and upon verifying the actual deactivation dates, PJM promptly filed this notice of cancellation.

Second, the requested relief is intended to address a limited set of circumstances and system reliability was not jeopardized as a result of PJM’s inability to timely comply with the Commission’s regulations under these circumstances. The Service Agreements were filed with the Commission and because PJM was not informed of the deactivation dates for the generation units at issue here until October 2019, PJM was not able to file the notices of cancellation until it

⁴ *Wisvest-Connecticut, L.L.C. v. ISO New England, Inc.*, 101 FERC ¶ 61,372 (2002); *Great Lakes Gas Transmission Limited Partnership*, 102 FERC ¶ 61,331 (2003).

⁵ *New York Independent System Operator, Inc.*, 112 FERC ¶ 61,347 (2005).

⁶ *Wisvest-Connecticut, L.L.C.*, *supra* n. 3.

⁷ *See, New York Independent System Operator, Inc.*, 125 FERC ¶ 61,005 (2008), *citing, Wisvest-Connecticut, L.L.C.*, *supra*, n. 3; *see also, PJM Interconnection, L.L.C.*, 125 FERC ¶ 61,279 (2008).

received this information. As pointed out above, there is no harmful impact on reliability or third parties as the parties have no remaining obligations under the Service Agreements. Moreover, since no additional requirements or payments were due under the Service Agreements and no third parties are impacted by their termination, there is no public notice impact in failing to file the notices of cancellation until today.

PJM also submits good cause exists for granting waiver as outlined in *Central Hudson*.⁸ In *Central Hudson*, the Commission stated that it would grant waiver of the prior notice requirements where the customer did not object to the filing and where the filing does not change rates.⁹ In addition, the Commission explicitly provided that it will generally grant waiver of the 60-day prior notice requirement in “uncontested filings that do not change rates – such as notices of cancellation when the contract expires by its own terms and the customer does not desire an extension.”¹⁰ Here, all parties support filing these late notices of cancellation. In addition, given the nature of such filings, they do not change rates. Thus, the *Central Hudson* requirements for waiver are satisfied.¹¹ Further, in the case of the DuPont Textiles ISA, an effective date consistent with the date on which the CIRs expired is consistent with the parties’ intent.

In summary, PJM has promptly filed this notice of cancellation upon verifying the applicable deactivation dates in October 2019. No other customers will be adversely affected since

⁸ *Central Hudson Gas & Electric Corp.*, 60 FERC ¶ 61,106, *reh’g denied*, 61 FERC ¶ 61,089 (1992) (“Central Hudson”).

⁹ *Id.* at 61,338.

¹⁰ *Id.* PJM appreciates the Commission’s warning in *Central Hudson* that a utility does not have an unlimited time period for filing a notice of cancellation. *Id.* at n. 9. PJM has taken steps to put a process in place to prevent future non-compliance.

¹¹ *See, e.g., Cleco Power LLC*, Letter Order, Docket No. ER11-3466-000 (June 14, 2011); *Midwest Indep. Transmission Sys. Operator, Inc.*, Letter Order Docket No. ER11-3499-000 (June 20, 2011); and *Arizona Public Service Company*, Letter Order, Docket No. ER11-413-000 (Sept. 14, 2011).

The Honorable Kimberly D. Bose, Secretary
PJM Interconnection, L.L.C.
November 6, 2019
Page 5

the activities provided under the Service Agreements ceased on the cancellation dates, thus FERC's regulatory oversight responsibilities are not at issue.

III. CORRESPONDENCE

The following individuals are designated for inclusion on the official service list in this proceeding and for receipt of any communications regarding this filing:

Craig Glazer
Vice President-Federal Government Policy
PJM Interconnection, L.L.C.
1200 G Street, N.W., Suite 600
Washington, D.C. 20005
(202) 423-4743
craig.glazer@pjm.com

Mark J. Stanisiz
Senior Counsel
PJM Interconnection, L.L.C.
2750 Monroe Blvd.
Audubon, PA 19403
(610) 666-4707
mark.stanisiz@pjm.com

IV. SERVICE

PJM has served a copy of this filing on the Interconnection Customers and Transmission Owners that are parties to the above Service Agreements, as well as the state utility regulatory commissions within the PJM region.

Respectfully submitted,

Craig Glazer
Vice President-Federal Government Policy
PJM Interconnection, L.L.C.
1200 G Street, N.W., Suite 600
Washington, D.C. 20005
(202) 423-4743
Craig.Glazer@pjm.com

By: /s/ Mark J. Stanisiz
Mark J. Stanisiz
Senior Counsel
PJM Interconnection, L.L.C.
2750 Monroe Blvd.
Audubon, Pennsylvania 19403
(610) 666-4707
Mark.Stanisiz@pjm.com

The Honorable Kimberly D. Bose, Secretary
PJM Interconnection, L.L.C.
November 6, 2019
Page 6

cc:

Mannington Mills, Inc.
PO Box 30
Salem, New Jersey 08079
Attn: Mr. Curtis Martin

Atlantic City Electric Company
Mail Stop #79NC58 P.O. Box 9239
Newark, DE 19714-9239
Attn: Director, Transmission Business Development

DuPont Sourcing-Raw Materials Energy & Packaging
Barley Mill Plaza 25/2154
P.O. Box 80025
Lancaster Pike & Route 1141
Wilmington, Delaware 19880-002

Delmarva Power & Light Company
Mail Stop #79NC58
P.O. Box 9239
Newark, DE 19714-9239
Attn: Director, Transmission Business Development

All state utility regulatory commissions within the PJM Region

FEDERAL ENERGY REGULATORY COMMISSION
WASHINGTON, D.C. 20426

Date: 3/26/04

To: PJM Interconnection, LLC

Docket No. ER04-585-000

Reference: PJM Interconnection, LLC Original Service Agreement No. 1012.

Pursuant to authority delegated to the Director, Division of Tariffs & Market Development - East, under 18 C.F.R. §375.307, your submittal for filing an executed Interconnection Service Agreement (ISA) among PJM Interconnection, LLC, Mannington Mills, Inc. and Atlantic City Electric Company, d/b/a Connectiv Power Delivery, (CPD) is accepted for filing effective January 27, 2004, as requested.

Notice of the filing was published in the Federal Register with comments, protests, or interventions due on or before March 17, 2004. No comments, protests, or interventions were filed.

This action does not constitute approval of any service, rate, charge, classification, or any rule, regulation, contract, or practice affecting such rate or service provided for in the filed documents; nor shall such action be deemed as recognition of any claimed contractual right or obligation affecting or relating to such service or rate; and such action is without prejudice to any findings or orders which have been or may hereafter be made by the Commission in any proceeding now pending or hereafter instituted by or against any of the applicant(s).

This order constitutes final agency action. Requests for rehearing by the Commission may be filed within 30 days of the date of issuance of this order, pursuant to 18 C.F.R. §385.713.

Sincerely,

Alice Fernandez, Director
Division of Tariffs and Market
Development – East

Deborah C. Brentani
brentani @ [wrightlaw.com](mailto:brentani@wrightlaw.com)

February 25, 2004

Honorable Magalie R. Salas
Secretary
Federal Energy Regulatory Commission
888 First Street, N.E., Room 1A
Washington, D.C. 20426

Re: PJM Interconnection, L.L.C., Docket No. ER04 _____

Dear Ms. Salas:

Pursuant to section 205 of the Federal Power Act, 16 U.S.C. § 824d, part 35 of the Commission's regulations, 18 C.F.R. part 35, and section 72.1 of Part IV of the PJM Open Access Transmission Tariff ("PJM Tariff"), PJM Interconnection, L.L.C. ("PJM") submits for filing an executed interconnection service agreement ("ISA") among PJM, Mannington Mills, Inc. ("Mannington") and Atlantic City Electric Company d/b/a Conectiv Power Delivery ("CPD").

The ISA among PJM, Mannington and CPD, designated as Original Service Agreement No. 1012 and filed herein, facilitates Mannington's request to interconnect to the PJM transmission system three 2.8 MW generators at a generating facility located in Salem, New Jersey. See Interconnection Service Agreement Between PJM

Interconnection, L.L.C. And Mannington Mills, Inc. And Atlantic City Electric Company d/b/a Conectiv Power Delivery, Specifications § 1.0 ("Original Service Agreement No. 1012"). Pursuant to Original Service Agreement No. 1012, the generating units shall be an Energy Resource, permitted to inject 8.4 MW into the PJM system. Id. Specifications § 2.1. Consequently, Mannington shall have no Capacity Interconnection Rights. Id. No charges are associated with Original Service Agreement No. 1012. Id. Specifications § 4.0. Additionally, Schedule G contains non-standard terms and conditions regarding release of confidential information to the Commission and/or its staff. Id. Schedule G.

Waiver and Effective Date

PJM requests a waiver of the Commission's 60-day prior notice requirement to allow an effective date of January 27, 2004 for Original Service Agreement No. 1012. See Original Service Agreement No. 1012 § 4.0. Waiver is appropriate because the agreement is being filed within thirty days of its requested effective date. See Prior Notice filing Requirements Under Part II of the Federal Power Act, 64 NERC 161,139, at 61,983-84 (1993).

Documents Enclosed

PJM encloses the original and six copies of the following:

1. Transmittal Letter.
2. Original Service Agreement No. 1012.
3. Federal Register Notice (also enclosed on diskette).

Correspondence and Communications

Correspondence and communications with respect to this filing should be sent to, and PJM requests the Secretary to include on the official service list, the following:

Craig Glazer
Vice President - Governmental Policy
PJM Interconnection, L.L.C.
1200 G Street, N.W.
Suite 600
Washington, D.C. 20005
(202) 393-7756

Barry S. Spector
Carrie L. Bumgarner
Wright & Talisman, P.C.
1200 G Street, N.W.
Suite 600
Washington, D.C. 20005
(202) 393-1200

Service and Federal Register Notice

PJM has served a copy of this filing on Mannington, CPD, and the state regulatory commissions within the PJM region. A form of notice suitable for publication in the Federal Register is attached and enclosed on diskette.

Respectfully submitted,

Barry S. Spector
Carrie L. Bumgarner
Deborah C. Brentani

Counsel for
PJM Interconnection, LLC

Interconnection Service Agreement

INTERCONNECTION SERVICE AGREEMENT

- 1.0 Parties. This Interconnection Service Agreement ("ISA"), dated as of November 17, 2003, including the Specifications, Schedules and Appendices attached hereto and incorporated herein, is entered into by and between PJM Interconnection, L.L.C., the Regional Transmission Organization for the PJM region (hereinafter "Transmission Provider"), Mannington Mills, Inc. ("Interconnection Customer") and Atlantic City Electric Company d/b/a Conectiv Power Delivery ("Interconnected Transmission Owner"). All capitalized terms herein shall have the meanings set forth in the appended definitions of such terms as stated in Part I or Part IV of the Tariff. This ISA shall supersede the "Parallel Agreement by and between Atlantic City Electric Company and Mannington Mills, Inc. Dated as of April 30, 2002".
- 2.0 Authority. This ISA is entered into pursuant to Part IV of the Tariff. Interconnection Customer has requested an Interconnection Service Agreement under the PJM Open Access Transmission Tariff ("Tariff"), and Transmission Provider has determined that Interconnection Customer is eligible under the Tariff to obtain this ISA. The standard terms and conditions for interconnection as set forth in Subpart E of Part IV of the Tariff as of the date of this ISA are attached as Appendix 2 to this ISA and are hereby specifically incorporated as provisions of this ISA. Transmission Provider, Interconnected Transmission Owner and Interconnection Customer agree to and assume all of the rights and obligations of the Transmission Provider, Interconnected Transmission Owner and Interconnection Customer, respectively, as set forth in the appended provisions of Subpart E.
- 3.0 Customer Facility Specifications. Attached are Specifications for the Customer Facility that Interconnection Customer proposes to interconnect with the Transmission System. Interconnection Customer represents and warrants that, upon completion of construction of such facilities, it will own or control the Customer Facility identified in section 1.0: of the Specifications attached hereto and made a part hereof. In the event that Interconnection Customer will not own the Customer Facility, Interconnection Customer represents and warrants that it is authorized by the owner(s) thereof to enter into this ISA and to represent such control.
- 4.0 Effective Date. This ISA shall become effective on the date it is executed by the Transmission Provider and shall terminate on such date as mutually agreed upon by the parties, unless earlier terminated in accordance with the appended terms of Subpart E. Interconnection Service shall commence as provided in Section 51.2 of the appended Subpart E.
- 5.0 Security. In accord with Section 36.8.4(b) or Section 41.7.3(b) of the Tariff, as applicable, Interconnection Customer, on or before the effective date of this ISA, shall provide the Transmission Provider (for the benefit of the Interconnected Transmission Owner) with a letter of credit from an agreed provider or other form of security reasonably acceptable to the Transmission Provider and that names the Transmission Provider as beneficiary ("Security") in the amount of \$ Q (Zero Dollars). This amount represents the estimated Cots, deteiinned in accordance with Section 37 or Section 42

of the Tariff, of the facilities described in Section 3.0 of the attached Specifications, plus the Costs of any Merchant Network Upgrades that Interconnected Transmission Owner is responsible for building pursuant to Subpart F of Part IV of the Tariff and the parties' Construction Service Agreement, less any Costs already paid by Interconnection Customer. Should Interconnection Customer fail to provide Security in the amount or form required in the first sentence of this section, this ISA shall be terminated. Interconnection Customer acknowledges that its ultimate cost responsibility in accordance with Section 37 or Section 42 of the Tariff will be based upon the actual Costs of the facilities described in the Specifications, whether greater or lesser than the amount of the payment security provided under this section.

6.0 Project Specific Milestones. In addition to the milestones stated in Section 36.8.5 or Section 41.7.4 of the Tariff, as applicable, during the term of this ISA, Interconnection Customer shall ensure that its Customer Facility meets each of the following development milestones:

6.1 Commercial Operation. i) On or before July 1, 2004, Interconnection Customer must demonstrate commercial operation of 3 generating units. Commercial operation demonstration includes the sale of energy and obtaining capacity qualification, if applicable, in accordance with the requirements of the PJM Reliability Assurance Agreement.

6.2 Within one (1) month following commercial operation of generating unit(s), Interconnection Customer must provide certified documentation demonstrating that "as-built" Customer Facility and Customer Interconnection Facilities are in accordance with applicable PJM studies and agreements. Interconnection Customer must also provide PJM with "as-built" electrical modelling data or confirm that previously submitted data remains valid.

Interconnection Customer shall demonstrate the occurrence of each of the foregoing milestones to Transmission Provider's reasonable satisfaction. Transmission Provider may reasonably extend any such milestone dates, in the event of delays that Interconnection Customer (i) did not cause and (ii) could not have remedied through the exercise of due diligence.

7.0 Provision of Interconnection Service. Transmission Provider and Interconnected Transmission Owner agree to provide for the interconnection to the Transmission System in the PJM region of Interconnection Customer's Customer Facility identified in the Specifications in accordance with Part IV of the Tariff, the Operating Agreement of PJM Interconnection, L.L.C. ("Operating Agreement"), and this ISA, as they may be amended from time to time.

8.0 Assumption of Tariff Obligations. Interconnection Customer agrees to abide by all rules and procedures pertaining to generation and transmission in the PJM Control Area and/or PJM West Region, including but not limited to the rules and procedures concerning the dispatch of generation or scheduling transmission set forth in the Tariff, the Operating Agreement and the PJM Manuals.

9.0 Facilities Study. In analyzing and preparing the Generation Interconnection Facilities Study, and in designing and constructing the Attachment Facilities, Local Upgrades and/or Network Upgrades described in the Specifications attached to this ISA, Transmission Provider, the Interconnected Transmission Owner(s), and any other subcontractors employed by Transmission Provider have had to, and shall have to, rely on information provided by Interconnection Customer and possibly by third parties and may not have control over the accuracy of such information. Accordingly, NEITHER TRANSMISSION PROVIDER, THE INTERCONNECTED TRANSMISSION OWNER(s), NOR ANY OTHER SUBCONTRACTORS EMPLOYED BY TRANSMISSION PROVIDER MAKES ANY WARRANTIES, EXPRESS OR IMPLIED, WHETHER ARISING BY OPERATION OF LAW, COURSE OF PERFORMANCE OR DEALING, CUSTOM, USAGE IN THE TRADE OR PROFESSION, OR OTHERWISE, INCLUDING WITHOUT LIMITATION IMPLIED WARRANTIES OF MERCHANTABILITY AND FITNESS FOR A PARTICULAR PURPOSE, WITH REGARD TO THE ACCURACY, CONTENT, OR CONCLUSIONS OF THE FACILITIES STUDY OR OF THE ATTACHMENT FACILITIES, THE LOCAL UPGRADES AND/OR THE NETWORK UPGRADES, PROVIDED, HOWEVER, that Transmission Provider warrants that the Transmission Owner Interconnection Facilities and any Merchant Transmission Upgrades described in the Specifications will be designed and constructed (to the extent that Interconnected Transmission Owner is responsible for design and construction thereof) and operated in accordance with Good Utility Practice, as such term is defined in the Operating Agreement. Interconnection Customer acknowledges that it has not relied on any representations or warranties not specifically set forth herein and that no such representations or warranties have formed the basis of its bargain hereunder.

10.0 Construction of Transmission Owner Interconnection Facilities

10.1. Cost Responsibility. Interconnection Customer shall be responsible for and shall pay upon demand all Costs associated with the interconnection of the Customer Facility as specified in the Tariff. These Costs may include, but are not limited to, an Attachment Facilities charge, a Local Upgrades charge, a Network Upgrades charge and other charges, as well as Costs of any Merchant Network Upgrades constructed on behalf of Interconnection Customer. A description of the facilities required and an estimate of the Costs of these facilities are included in Sections 3.0 and 4.0 of the Specifications to this ISA.

10.2. Billing and Payments. The Transmission Provider shall bill the Interconnection Customer for the Costs associated with the facilities contemplated by this ISA, and the Interconnection Customer shall pay such Costs, in accordance with the terms of Subpart F of Part IV of the Tariff. Upon receipt of each of Interconnection Customer's payments of such bills, Transmission Provider shall reimburse the applicable Interconnected Transmission Owner

10.3 Contract Option. In the event that the Interconnection Customer and Interconnected Transmission Owner agree to utilize the Negotiated Contract Option provided by Section 83.2.2 of Subpart F of Part IV of the Tariff to

establish, subject to FERC acceptance, non-standard terms regarding cost responsibility, payment, billing, and/or financing, the terms of Section 10.1 and/or 10.2 of this Section 10.0 shall be superseded to the extent required to conform to such negotiated terms, as stated in a schedule attached to the parties' Construction Service Agreement relating to interconnection of the Customer Facility.

Not Applicable.

10.4 In the event that the Interconnection Customer elects to construct some or all of the Transmission Owner Interconnection Facilities and/or of any Merchant Network Upgrades under the Option to Build of Section 83.2.3 of Subpart F of Part IV of the Tariff, the charges under Section 13.0 below and billing and payment under Section 10.2 above shall relate only to such portion of the Interconnection Facilities and/or any Merchant Network Upgrades as the Interconnected Transmission Owner is responsible for building.

11.0 Interconnection Specifications

11.1 Point of Interconnection. The Point of Interconnection shall be as identified on the one-line diagram attached as Schedule B to this ISA.

11.2 List and Ownership of Interconnection Facilities. The Interconnection Facilities to be constructed and ownership of the components thereof are identified in Section 3.0 of the Specifications attached to this ISA. The Customer Interconnection Facilities and the Transmission Owner Interconnection Facilities are identified on the attached Schedule C to this ISA.

11.2A Local and Ownership of Merchant Network Upgrades. Not applicable.

11.3 Ownership and Location of Metering Equipment. The Metering Equipment to be constructed, and the ownership thereof, are identified on the attached Schedule D to this ISA.

11.4 Applicable Technical Standards. The Applicable Technical Requirements and Standards that apply to the Customer Facility and the Interconnection Facilities are attached as Schedule E to this ISA.

12.0 Operational Requirements.

12.1 The Maximum Facility Output of the Customer Facility is 8.4 MW.

13.0 Charges.

Not Applicable.

14.0 Third Party Beneficiaries. No third party beneficiary rights are created under this ISA, except, however, that, subject to modification of the payment terms stated in Section 10 of this ISA pursuant to the Negotiated Contract Option, payment obligations imposed on Interconnection Customer under this ISA are agreed and acknowledged to be for the

benefit of the Interconnected Transmission Owner(s). Interconnection Customer expressly agrees that the Interconnected Transmission Owner(s) shall be entitled to take such legal recourse as it deems appropriate against Interconnection Customer for the payment of any Costs or charges authorized under this ISA or the Tariff with respect to Interconnection Service for which Interconnection Customer fails, in whole or in part, to pay as provided in this ISA, the Tariff and/or the Operating Agreement.

- 15.0 Waiver. No waiver by either party of one or more defaults by the other in performance of any of the provisions of this ISA shall operate or be construed as a waiver of any other or further default or defaults, whether of a like or different character.
- 16.0 Amendment. This ISA or any part thereof, may not be amended, modified, assigned, or waived other than by a writing signed by all parties hereto.
- 17.0 Construction With Other Parts Of The Tariff. This ISA shall not be construed as an application for service under Part II or Part III of the Tariff.
- 18.0 Notices. Any notice or request made by either party regarding this ISA shall be made, in accordance with the terms of the appended Subpart E, to the representatives of the other party and as applicable, to the Interconnected Transmission Owner(s), as indicated below:

Transmission Provider:
PJM Interconnection, L.L.C.
955 Jefferson Avenue
Valley Forge Corporate Center
Norristown, PA 19403-2497

Interconnection Customer:

Mannington Mills, Inc.
PO Box 30. (US Mail)
75 Mannington Mills Road (overnight mail)
Salem, New Jersey 08079 Attn: Mr. Curtis
Martin

Interconnected Transmission Owner:

Atlantic City Electric Company
Mail Stop #79NC58
P.O. Box 9239 (US Mail)
401 Eagle Run Road (overnight mail)
Newark, DE 19714-9239
Attn: Director, Transmission Business Development
Facsimile: 302-454-4161
Telephone: 302-454-4936

19.0 Incorporation Of Other Documents.. All portions of the Tariff and the Operating Agreement pertinent to the subject matter of this ISA and not otherwise made a part hereof are hereby incorporated herein and made a part hereof.

20.0 Addendum of Non-Standard Temis and Conditions for Interconnection Service. Subject to FERC approval, the parties agree that the temis and conditions set forth in Schedule G hereto are hereby incorporated herein by reference and be made a part of this ISA. In the event of any conflict between a provision of Schedule G that FERC has accepted and any provision of the appended Subpart E that relates to the same subject matter, the pertinent provision of Schedule G shall control.

IN WITNESS WHEREOF, Transmission Provider, Interconnection Customer and Interconnected Transmission Owner have caused this ISA to be executed by their respective authorized officials.

Transmission Provider:

By: Joseph S. Davis General Manager - Business Services 1/27/04
Name Title Date

Interconnection Customer:

Name Title Date

Interconnected Transmission Owner: B i/2-.3~0
Name Title Date

(Queue #K01)
**SPECIFICATIONS FOR
INTERCONNECTION SERVICE AGREEMENT
Between
PJM INTERCONNECTION, L.L.C.
And
MANNINGTON MILLS, INC.
And
ATLANTIC CITY ELECTRIC COMPANY
D/BIA CONECTIV POWER DELIVERY**

1.0 Description of generating units (the Customer Facility) to be interconnected with the Transmission System in the PJM region:

a. Name of Customer Facility:

Mannington Mills Units 1, 2 and 3 (a/k/a PJM Generation Interconnection Queue #K01).

b. Location of Customer Facility:

75 Mannington Mills Road, Salem, New Jersey c.

Size in megawatts of Customer Facility:

for Generation Interconnection Customer:

Maximum Facility Output 8.4 MW d.

Description of the equipment configuration:

Three 2.8 megawatt gas-fueled generators.

2.0 Rights

2.1 The generating unit(s) described in section 1.0 shall be an Energy Resource. Pursuant to this Interconnection Service Agreement, the generating unit will be permitted to inject 8.4 MW into the system. PJM reserves the right to limit injections to this quantity in the event reliability would be affected by output greater than such quantity.

3.0 Construction Responsibility

a. Interconnection Customer. In the event that, in accordance with Section 83.2.3 of Subpart F of the Tariff, Interconnection Customer has exercised the Option to Build, it is hereby permitted to build in accordance with and subject to the conditions and limitations set forth in that Section, the following portions of the Transmission Owner Interconnection Facilities and/or of any Merchant Network Upgrades which constitute or are part of the Customer Facility:

Not Applicable

b. Atlantic City Electric Company d/b/a Conectiv Power Delivery.

None.

4.0 Subject to modification pursuant to the Negotiated Contract Option and/or the Option to

Build under Section 83.2 of Subpart F of Part IV of the Tariff, Interconnection Customer shall be subject to the charges detailed below:

4.1 Attachment Facilities Charge: None

4.2 Network Upgrades Charge: None 4.3

Local Upgrades Charge: None 4.4 Other

Charges: None

4.5 Cost of Merchant Network Upgrade: N/A 4.6

Cost breakdown: N/A

4.7 Guaranty amount required: N/A

4.8 Guaranty Reduction Schedule: N/A

APPENDICES:

- APPENDIX 1-DEFINITIONS
- APPENDIX 2 - SUBPART E TERMS AND CONDITIONS

SCHEDULES:

- SCHEDULE A - CUSTOMER FACILITY LOCATION/SITE PLAN
- SCHEDULE B - SINGLE-LINE DIAGRAM
- SCHEDULE C - LIST AND OWNERSHIP OF FACILITIES
- SCHEDULE D - OWNERSHIP AND LOCATION OF METERING EQUIPMENT
- SCHEDULE E - APPLICABLE TECHNICAL REQUIREMENTS AND STANDARDS
- SCHEDULE F - SCHEDULE OF CHARGES
- SCHEDULE G - ADDENDUM OF NON-STANDARD TERMS & CONDITIONS FOR INTERCONNECTION SERVICE

APPENDIX 1

DEFINITIONS

Tariff Section	Definition
-----------------------	-------------------

- 50.1** "Abnormal Condition" shall mean any condition on the Interconnection Facilities which, determined in accordance with Good Utility Practice, is: (i) outside normal operating parameters such that facilities are operating outside their normal ratings or that reasonable operating limits have been exceeded; and (ii) could reasonably be expected to materially and adversely affect the safe and reliable operation of the Interconnection Facilities; but which, in any case, could reasonably be expected to result in an Emergency Condition. Any condition or situation that results from lack of sufficient generating capacity to meet load requirements or that results solely from economic conditions shall not, standing alone, constitute an Abnormal Condition.
- 50.2** "Affiliate" shall mean, with respect to a corporation, partnership or other entity, each such other corporation, partnership or other entity that directly or indirectly, through one or more intermediaries, controls, is controlled by, or is under common control with, such corporation, partnership or other entity.
- 1.1** **Ancillary Services:** Those services that are necessary to support the transmission of capacity and energy from resources to loads while maintaining reliable operation of the Transmission Provider's Transmission System in accordance with Good Utility Practice.
- 50.3** "Applicable Laws and Regulations" shall mean all duly promulgated applicable federal, state and local laws, regulations, rules, ordinances, codes, decrees, judgments, directives, or judicial or administrative orders, permits and other duly authorized actions of any Governmental Authority having jurisdiction over the relevant parties, their respective facilities, and/or the respective services they provide.
- 50.4** "Applicable Reliability Council" shall mean (MAAC) in the case of the PJM Control Area and ECAR with respect to PJM West Region.
- 50.5** "Applicable Standards" shall mean the requirements and guidelines of NERC, the Applicable Reliability Council and the Control Area in which the Customer Facility is electrically located, the PJM Manuals and Applicable Technical Requirements and Standards.
- 50.6** "Applicable Technical Requirements and Standards" shall mean those certain technical requirements and standards applicable to interconnections of generation and/or transmission facilities with the facilities of an Interconnected Transmission Owner, as published by Transmission Provider in a PJM Manual. Such Applicable Technical Requirements and Standards shall be publicly available through postings on Transmission Provider's internet website.
- 1.3A Attachment Facilities:** The facilities necessary to physically connect a Customer Facility to the Transmission System or interconnected distribution facilities.
- 50.7** "Breach" shall mean the failure of a party to perform or observe any material term or condition of the applicable Subpart of Part IV of the Tariff or an agreement entered into thereunder as described in the relevant provisions of Subpart E or Subpart F.

Tariff Section	Definition
-----------------------	-------------------

50.8 "Breaching Party" shall mean an Interconnected Entity or a Construction Party that is in Breach of the applicable Subpart and/or an agreement entered into thereunder.

50.9 "Cancellation Costs" shall mean the Costs and liabilities incurred in connection with: (a) cancellation of supplier and contractor written orders and agreements entered into to design, construct and install the Transmission Owner Interconnection Facilities and/or Merchant Network Upgrades; and/or (b) completion of some or all of the Transmission Owner Interconnection Facilities and/or Merchant Network Upgrades, or specific unfinished portions and/or removal of any or all of such facilities which have been installed, to the extent required for the Transmission Provider and/or Interconnected Transmission Owner to perform their respective obligations under Part IV of the Tariff.

1.3C Capacity Interconnection Rights: The rights to input [generation.as](#) a Capacity Resource or Available Capacity Resource into the Transmission System at the bus where the generating facilities connect to the Transmission System..

1.3E Capacity Transmission Injection Rights: The rights to schedule energy and capacity deliveries at a Point of Interconnection (as defined' in Section 50.44) of a Merchant Transmission Facility with the Transmission System. Capacity Transmission Injection Rights may be awarded only to a Merchant D.C. Transmission Facility that connects the Transmission System to another control area. Deliveries scheduled using Capacity Transmission Injection Rights have rights similar to those under Firm Point-to-Point Transmission Service or, if coupled with a generating unit external to the combined PJM Control Area and PJM West Region that satisfies all applicable criteria specified in the PJM Manuals, similar to Capacity Interconnection Rights.

50.10 "Commencement Date" shall mean the date on which Interconnection Service commences in accordance with Section 51.2 of Subpart E.

1.4 Commission: The Federal Energy Regulatory Commission.

50.11 "Confidential Information" shall mean any confidential, proprietary, or trade secret information of a plan, specification, pattern, procedure, design, device, list, concept, policy, or compilation relating to the present or planned business of an Interconnection Party or Construction Party, which is designated as confidential by the party supplying the information, whether conveyed verbally, electronically, in writing, through inspection, or otherwise, and shall include, without limitation, all information relating to the producing party's technology, research and development, business affairs and pricing, and any information supplied by any Interconnection Party or Construction Party to another such party prior to the execution of an Interconnection Service Agreement or a Construction Service Agreement.

50.12 "Constructing Entity" shall mean either the Interconnected Transmission Owner or the Interconnection Customer, depending on which entity has the construction responsibility pursuant to Subpart F, and shall also be used to refer to an Interconnection Customer with respect to the construction of the Customer Interconnection Facilities.

Tariff Section Definition

50.13 "Construction Party" shall mean the Interconnection Customer, the Interconnected Transmission Owner, or Transmission Provider. "Construction Parties" shall mean all of them.

50.14 "Construction Service Agreement" shall mean that agreement entered into by Interconnection Customer, Interconnected Transmission Owner and Transmission Provider, applicable to the Customer Facility and implementing the terms and conditions of Subpart F of Part IV of the Tariff.

50.15 "Costs" shall mean costs and expenses, including, but not limited to, capital expenditures, if applicable, and overhead, return, and the costs of financing and taxes and any Incidental Expenses as defined below. Costs are calculated on a time and materials basis, including overhead.

1.7A Customer Facility: Generation facilities or Merchant Transmission Facilities interconnected with or added to the Transmission System pursuant to an Interconnection Request under Subparts A or B of Part IV of the Tariff.

50.15A "Customer Interconnection Facilities" shall mean all facilities and equipment owned and/or controlled, operated and maintained by Interconnection Customer on Interconnection Customer's side of the Point of Interconnection identified in the appropriate appendices to the Interconnection Service Agreement and to the Construction Service Agreement, including any modifications, additions, or upgrades made to such facilities and equipment, that are necessary to physically and electrically interconnect the Customer Facility with the Transmission System.

50.16 "Default" shall mean the failure of a Breaching Party to cure its Breach in accordance with the applicable provisions of Subpart E or Subpart F.

50.17 "SCAR" shall mean East Central Area Reliability Council Agreement, a regional reliability council of NERC, or its successor.

50.18 "Emergency Condition" shall mean a condition or situation (i) that in the judgment of any Interconnection Party is imminently likely to endanger life or property; or (ii) that in the judgment of the Interconnected Transmission Owner or Transmission Provider is imminently likely (as determined in a nondiscriminatory manner) to cause a material adverse effect on the security of, or damage to, the Transmission System, the Interconnection Facilities, or the transmission systems or distribution systems to which the Transmission System is directly or indirectly connected; or (iii) that in the judgment of Interconnection Customer is imminently likely (as determined in a non-discriminatory manner) to cause damage to the Customer Facility or to the Customer Interconnection Facilities. System restoration and black start shall be considered Emergency Conditions, provided that a Generation Interconnection Customer is not obligated by Subpart E of Part IV of the Tariff to possess black start capability. Any condition or situation that results from lack of sufficient generating capacity to meet load requirements or that results solely from economic conditions shall not constitute an Emergency Condition, unless one or more of the enumerated conditions or situations identified in this definition also exists.

1.11A Energy Resource: A generating facility that is not a Capacity Resource Available or Capacity Resource. ,

Tariff Section Definition

1.11B Energy Transmission Injection Rights: The rights to schedule energy deliveries at a specified point on the Transmission System. Energy Transmission Injection Rights may be awarded only to a Merchant D.C. Transmission Facility that connects the Transmission System to another control area. Deliveries scheduled using Energy Transmission Injection Rights have rights similar to those under Non-Firm Point-to-Point Transmission Service.

50.19' "Environmental Laws" shall mean Applicable Laws or Regulations relating to pollution or protection of the environment, natural resources or human health and safety.

50.20 "Facilities Study" shall mean that certain Generation Interconnection Facilities Study or Transmission Interconnection Facilities Study conducted by Transmission Provider (or at its direction) to determine the design and specification of the Interconnection Facilities necessary to accommodate the interconnection of the Customer Facility with the Transmission System in accordance with Section 36.6 or Section 41.5 of the Tariff, as applicable.

50.21 [**Reserved**]

50.22 "Federal Power Act" shall mean the Federal Power Act, as amended, 16 U.S.C. §§ 791a, et seq.

50.23 " NERC shall mean the Federal Energy Regulatory Commission or its successor.

1.13A Firm Transmission Withdrawal Rights: The rights to schedule energy and capacity withdrawals from a Point of Interconnection (as defined in Section 50.44) of a Merchant Transmission Facility with the Transmission System. Firm Transmission Withdrawal Rights may be awarded only to a Merchant D.C. Transmission Facility that connects the Transmission System with another control area. Withdrawals scheduled using Firm Transmission Withdrawal Rights have rights similar to those under Firm Point-to-Point Transmission Service.

50.24 "Force Majeure" shall mean any cause beyond the control of the affected Interconnection Party or Construction Party, including but not restricted to, acts of God, flood, drought, earthquake, storm, fire, lightning, epidemic, war, riot, civil disturbance or disobedience, labor dispute, labor or material shortage, sabotage, acts of public enemy, explosions, orders, regulations or restrictions imposed by governmental, military, or lawfully established civilian authorities, which, in any of the foregoing cases, by exercise of due diligence such party could not reasonably have been expected to avoid, and which, by the exercise of due diligence, it has been unable to overcome. Force Majeure does not include (i) a failure of performance that is due to an affected party's own negligence or intentional wrongdoing; (ii) any removable or remediable causes (other than settlement of a strike or labor dispute) which an affected party fails to remove or remedy within a reasonable time; or (iii) economic hardship of an affected party.

50.25 [**Reserved**]

1.13B Generation Interconnection Customer: An entity that submits an Interconnection Request to interconnect a new generation facility or to increase

the capacity of an existing generation facility interconnected with the Transmission System in the PJM Control Area or PJM West Region.

1.13C Generation Interconnection Facilities Study: A Facilities Study related to a Generation Interconnection Request.

1.13D Generation Interconnection Feasibility Study: A study conducted by the Transmission Provider (in coordination with the affected Transmission Owner(s)) in accordance with Section 36.2 of this Tariff.

1.13E Generation Interconnection Request: A request by a Generation Interconnection Customer pursuant to Subpart A of Part IV of the Tariff to interconnect a generating unit with the Transmission System or to increase the capacity of a generating unit interconnected with the Transmission System in the PJM Control Area or PJM West Region.

1.14 Good Utility Practice: Any of the practices, methods and acts engaged in or approved by a significant portion of the electric utility industry during the relevant time period, or any of the practices, methods and acts which, in the exercise of reasonable judgment in light of the facts known at the time the decision was made, could have been expected to accomplish the desired result at a reasonable cost consistent with good business practices, reliability, safety and expedition. Good Utility Practice is not intended to be limited to the optimum practice, method, or act to the exclusion of all others, but rather to be acceptable practices, methods, or acts generally accepted in the region.

50.26 "Governmental Authority" means any federal, state, local or other governmental, regulatory or administrative agency, court, commission, department, board, or other governmental subdivision, legislature, rulemaking board, tribunal, arbitrating body, or other governmental authority having jurisdiction over any Interconnection Party or Construction Party or regarding any matter relating to Subpart E or Subpart F, as applicable.

50.27 "Hazardous Substances" shall mean any chemicals, materials or substances defined as or included in the definition of "hazardous substances," "hazardous wastes," "hazardous materials," "hazardous constituents," "restricted hazardous materials," "extremely hazardous substances," "toxic substances," "radioactive substances," "contaminants," "pollutants," "toxic pollutants" or words of similar meaning and regulatory effect under any applicable Environmental Law, or any other chemical, material or substance, exposure to which is prohibited, limited or regulated by any applicable Environmental Law.

50.28 "Incidental Expenses" shall mean those expenses incidental to the performance of construction pursuant to Subpart F, including, but not limited to, the expense of temporary construction power, telecommunications charges, Interconnected Transmission Owner expenses associated with, but not limited to, document preparation, design review, installation, monitoring, and construction related operations and maintenance for the Customer Facility and for the Interconnection Facilities.

Tariff Section	Definition
-----------------------	-------------------

1.14B Incremental Auction Revenue Rights: The additional" Auction Revenue Rights (as defined in Section 1.3.1 of Attachment K to the Tariff), not previously feasible, created by the addition of Merchant Transmission Facilities, or a new transmission facility or upgrade resulting from the accommodation of an Interconnection Request pursuant to Part IV of the Tariff.

1.14C Incremental Available Transfer Capability Revenue Rights: The rights to revenues that are derived from incremental Available Transfer Capability created by the addition of a Merchant Transmission Facility or a new transmission facility or upgrade resulting from the accommodation of an Interconnection Request(s) pursuant to Part IV of the Tariff.

1.14D Incremental Deliverability Rights (IDRs): The rights to the incremental ability, resulting from the addition of a Merchant Transmission Facility, to inject energy and capacity at a point on the Transmission System, such that the injection satisfies the deliverability requirements of a Capacity Resource. Incremental Deliverability Rights may be obtained by a generator or a Generation Interconnection Customer, pursuant to an IDR Transfer Agreement, to satisfy, in part, the deliverability requirements necessary to obtain Capacity Interconnection Rights.

50.29 "Initial Operation" shall mean the commencement of operation of the Customer Facility and Customer Interconnection Facilities after satisfaction of the conditions of Section 51.4.

50.30 "Interconnected Entity" shall mean either the Interconnection Customer or the Interconnected Transmission Owner; "Interconnected Entities" shall mean both of them.

50.31 "Interconnected Transmission Owner" shall mean the Transmission Owner to whose transmission facilities the Customer Interconnection Facilities are, or as the case may be, the Customer Facility is, being directly connected. As used in Subpart F, the term also includes a Transmission Owner whose facilities must be upgraded pursuant to the Facilities Study, but whose facilities are not directly interconnected with those of the Interconnection Customer.

50.32 [Reserved]

1.14E Interconnection Customer: A Generation Interconnection Customer and/or a Transmission Interconnection Customer.

50.33 "Interconnection Facilities" shall mean the Transmission Owner Interconnection Facilities and the Customer Interconnection Facilities.

50.34 "Interconnection Party" shall mean Transmission Provider, Interconnection Customer, or the Interconnected Transmission Owner. "Interconnection Parties" shall mean all of them.

50.35 [Reserved]

1.14H Interconnection Request: A Generation Interconnection Request, a Transmission Interconnection Request and/or an IDR Transfer Agreement.

Tariff Section	Definition
-----------------------	-------------------

50.36 "Interconnection Service" shall mean the physical and electrical interconnection of the Customer Facility with the Transmission System pursuant to the terms of Part IV of the Tariff and the Interconnection Service Agreement entered into pursuant thereto by Interconnection Customer, the Interconnected Transmission Owner and Transmission Provider.

50.37 "List of Approved Contractors" shall mean a list developed by each Transmission Owner and published in a PJM Manual of (a) contractors that the Transmission Owner considers to be qualified to install or construct new facilities and/or upgrades or modifications to existing facilities on the Transmission Owner's system, provided that such contractors may include, but need not be limited to, contractors that, in addition to providing construction services, also provide design and/or other construction-related services, and (b) manufacturers or vendors of major transmission-related equipment (e.g., high-voltage transformers, transmission line, circuit breakers) whose products the Transmission Owner considers acceptable for installation and use on its system.

1.17A Local Upgrades: Modifications or additions of facilities to abate any local thermal loading, voltage, short circuit, stability or similar engineering problem caused by the interconnection and delivery of generation to the Transmission System.

50.38 "MAAC" shall mean the Mid Atlantic Area Council, a regional reliability council of NERC, or its successor.

50.39 "Maximum Facility Output" shall mean the maximum net electrical power output in megawatts, specified in the Interconnection Service Agreement, after supply of any parasitic or host facility loads, that the Customer Facility is expected to produce.

1.18B Merchant A.C. Transmission Facilities: Merchant Transmission Facilities that are alternating current (A.C.) transmission facilities.

1.18C Merchant D.C. Transmission Facilities: Merchant Transmission Facilities that are direct current (D.C.) transmission facilities.

1.18D Merchant Network Upgrades: Merchant A.C. Transmission Facilities that are additions to, or modifications or replacements of, physical facilities of the Interconnected Transmission Owner (as defined in Section 50.31 below) that, on the date of the pertinent Transmission Interconnection Customer's Interconnection Request, are part of the Transmission System or are included in the Regional Transmission Expansion Plan.

1.18E Merchant Transmission Facilities: A.C. or D.C. transmission facilities that are interconnected with or added to the Transmission System pursuant to Subpart B of Part IV of the Tariff and that are so identified on Attachment T to the Tariff, provided, however, that Merchant Transmission Facilities shall not include (i) any Customer Interconnection Facilities (as defined in Section 50.15A), (ii) any physical facilities of the Transmission System that are in existence on the date this provision is filed with the Commission; (iii) any expansions or enhancements of the Transmission System that are not identified as Merchant Transmission

Tariff Section	Definition
-----------------------	-------------------

Facilities in the Regional Transmission Expansion Plan and Attachment T to the Tariff, or (iv) any transmission facilities that are included in the rate base of a public utility and on which a regulated return is earned.

50.40 "Metering Equipment" shall mean all metering equipment installed at the metering points designated in the appropriate appendix to an Interconnection Service Agreement.

50.41 "NERC" shall mean the North American Electric Reliability Council, or its successor agency assuming or charged with similar responsibilities related to the operation and reliability of the North American interconnected electric transmission grid.

1.26 Network Upgrades: Modifications or additions to transmission-related facilities that are integrated with and support the Transmission Provider's overall Transmission System for the general benefit of all users of such Transmission System.

50.42 "Nominal Rated Capability" shall mean the nominal maximum rated capability in megawatts of a Transmission Interconnection Customer's Customer Facility or the nominal increase in transmission capability in megawatts of the Transmission System resulting from the interconnection or addition of a Transmission Interconnection Customer's Customer Facility, as determined in accordance with pertinent Applicable Standards and specified in the Interconnection Service Agreement.

1.27A Non-Firm Transmission Withdrawal Rights: The rights to schedule energy withdrawals from a specified point on the Transmission System. Non-Firm Transmission Withdrawal Rights may be awarded only to a Merchant D.C. Transmission Facility that connects the Transmission System to another control area. Withdrawals scheduled using Non-Firm Transmission Withdrawal Rights have rights similar to those under Non-Firm Point-to-Point Transmission Service.

1.28A Operating Agreement of the PJM Interconnection, L.L.C. or Operating Agreement: That agreement dated as of April 1, 1997 and as amended and restated as of June 2, 1997 and as amended from time to time thereafter, among the members of the PJM Interconnection, L.L.C.

50.43 "Option to Build" shall mean the option of the Interconnection Customer to build certain Transmission Owner Interconnection Facilities and/or Merchant Network Upgrades, as set forth in, and subject to the terms of, Section 83.2.3 of Subpart F.

1.29 Part I: Tariff Definitions and Common Service Provisions contained in Sections 2 through 12.

1.30 Part II: Tariff Sections 13 through 27 pertaining to Point-To-Point Transmission Service in conjunction with the applicable Common Service Provisions of Part I and appropriate Schedules and Attachments.

Tariff Section	Definition
-----------------------	-------------------

1.31 Part III: Tariff Sections 28 through 35 pertaining to Network Integration Transmission Service in conjunction with the applicable Common Service Provisions of Part I and appropriate Schedules and Attachments.

1.31A Part IV: Tariff Sections 36 through 112 pertaining to generation or merchant transmission interconnection to the Transmission System in conjunction with the applicable Common Service Provisions of Part I and appropriate Schedules and Attachments.

1.32B PJM Control Area: The Control Area that is recognized by NERC as the PJM Control Area.

1.32D PJM Manuals: The instructions, rules, procedures and guidelines established by the Transmission Provider for the operation, planning, and accounting requirements of the PJM region and the PJM Interchange Energy Market.

1.32F PJM West Region: The aggregate of the zone of the West Transmission Owners.

50.44 "Point of Interconnection" shall mean the point or points, shown in the appropriate appendix to the Interconnection Service Agreement and the Construction Service Agreement, where the Customer Interconnection Facilities and/or Merchant Network Upgrade(s) interconnect with the Transmission Owner

Interconnection Facilities or the Transmission System.

50.45 "Project Financing" means:

- (a) one or more loans, leases, equity and/or debt financings, together with all modifications, renewals, supplements, substitutions and replacements thereof, the proceeds of which are used to finance or refinance the costs of the Customer Facility, any alteration, expansion or improvement to the Customer Facility, the purchase and sale of the Customer Facility or the operation of the Customer Facility;
- (b) a power purchase agreement pursuant to which Interconnection Customer's obligations are secured by a mortgage or other lien on the Customer Facility; or
- (c) loans and/or debt issues secured by the Customer Facility.

50.46 "Project Finance Entity" means (a) a holder, trustee or agent for holders, of any component of Project Financing, or (b) any purchaser of capacity and/or energy produced by the Customer Facility to which Interconnection Customer has granted a mortgage or other lien as security for some or all of Interconnection Customer's obligations under the corresponding power purchase agreement.

50.47 "Reasonable Efforts" shall mean, with respect to any action required to be made, attempted, or taken by an Interconnection Party under Subpart E or by a Construction Party under Subpart F, such efforts as are timely and consistent with Good Utility Practice and with efforts that such party would undertake for the protection of its own interests.

Tariff Section	Definition
-----------------------	-------------------

1.37A **Regional Transmission Expansion Plan:** The plan prepared by the Office of the Interconnection pursuant to Schedule 6 of the Operating Agreement for the enhancement and expansion of the Transmission System in order to meet the demands for firm transmission service in the PJM region

50.48 [Reserved]

50.49 "Schedule of Payments" shall mean that schedule, as revised from time to time as necessary for correlation with the Schedule of Work, attached to the Construction Service Agreement and setting forth the payments due and owing by the Interconnection Customer pursuant to Subpart F.

50.50 "Schedule of Work" shall mean that schedule, as revised from time to time and attached to the Construction Service Agreement, setting forth the timing of work to be performed by the Constructing Entity pursuant to Subpart F and based upon the Facilities Study.

50.51 "Scope of Work" shall mean that scope of the work attached as a schedule to the Construction Service Agreement and to be performed by the Constructing Entity(ies) pursuant to Subpart F.

50.52 "Secondary Systems" shall mean control or power circuits that operate below 600 volts, AC or DC, including, but not limited to, any hardware, control or protective devices, cables, conductors, electric raceways, secondary equipment panels, transducers, batteries, chargers, and voltage and current transformers.

50.53 "Security" shall mean the security provided by the Interconnection Customer pursuant to Section 36.8.4 or Section 47.7.4 of the Tariff to secure the Interconnection Customer's responsibility for Costs under Subpart F and Section 37 or Section 42 of the Tariff.

50.54 "Site" shall mean all of the real property, including but not limited to any leased real property and easements, on which the Customer Facility is situated and/or on which the Customer Interconnection Facilities are to be located.

(Attachment K - Appendix)

13.33B Station Power.

"Station Power" shall mean energy used for operating the electric equipment on the site of a generation facility located in the PJM Control Area or for the heating, lighting, air-conditioning and office equipment needs of buildings on the site of such a generation facility that are used in the operation, maintenance, or repair of the facility. Station Power does not include any energy used to power synchronous condensers, used for pumping at a pumped storage facility, or used in association with restoration or black start service.

50.55 "Subpart E" shall refer to Subpart E of Part IV of the Tariff and, where the context so requires, to the Interconnection Service Agreement.

Tariff Section Definition

50.56 "Subpart F" shall refer to Subpart F of Part IV of the Tariff, and, where the context so requires, to the Construction Service Agreement.

50.57 "Switching and Tagging Rules" shall mean the switching and tagging procedures of Interconnected Transmission Owners and Interconnection Customer, as set forth in an appendix to the Interconnection Service Agreement, and as they may be amended from time to time.

50.58 "System Protection Facilities" shall mean the equipment required to protect (i) the Transmission System, other delivery systems and/or other generating systems connected to the Transmission System from faults or other electrical disturbance occurring at or on the Customer Facility, and (ii) the Customer Facility from faults or other electrical system disturbance occurring on the Transmission System or on other delivery systems and/or other generating systems to which the Transmission System is directly or indirectly connected. System Protection Facilities shall include such protective and regulating devices as are identified in the Applicable Technical Requirements and Standards or that are required by Applicable Laws and Regulations or other Applicable Standards, or as are otherwise necessary to protect personnel and equipment and to minimize deleterious effects to the Transmission System arising from the Customer Facility.

1.45A Transmission Injection Rights: Capacity Transmission Injection Rights and Energy Transmission Injection Rights.

1.45B Transmission Interconnection Customer: An entity that submits an Interconnection Request to interconnect or add Merchant Transmission Facilities to the Transmission System or to increase the capacity of Merchant Transmission Facilities interconnected with the Transmission System in the PJM Control Area or PJM West Region.

1.45C Transmission Interconnection Facilities Study: A Facilities Study related to a Transmission Interconnection Request.

1.45D Transmission. Interconnection Feasibility Study: A study conducted by the Transmission Provider in accordance with Section 41.2 of the Tariff.

1.45E Transmission Interconnection Request: A request by a Transmission Interconnection Customer pursuant to Part IV of the Tariff to interconnect or add Merchant Transmission Facilities to the Transmission System or to increase the capacity of existing Merchant Transmission Facilities interconnected with the Transmission System in the PJM Control Area or PJM West Region.

1.45F Transmission Owner: Each entity that owns, leases or otherwise has a possessory interest in facilities used for the transmission of electric energy in interstate commerce under the Tariff. The Transmission Owners are listed in Attachment L.

50.59 "Transmission Owner Attachment Facilities" shall mean that portion of the Transmission Owner Interconnection Facilities comprised of all Attachment Facilities on the Interconnected Transmission Owner's side of the Point of Interconnection.

Tariff Section	Definition
-----------------------	-------------------

50.60 "Transmission Owner Interconnection Facilities" shall mean all Interconnection Facilities that are not Customer Interconnection Facilities and that, after the transfer under Section 85.5 below to the Interconnected Transmission Owner of title to any Transmission Owner Interconnection Facilities that the Interconnection Customer constructed, are owned, controlled, operated and maintained by the Interconnected Transmission Owner on the Interconnected Transmission Owner's side of the Point of Interconnection identified in appendices to the Interconnection Service Agreement and to the Construction Service Agreement, including any modifications, additions or upgrades made to such facilities and equipment, that are necessary to physically and electrically interconnect the Customer Facility with the Transmission System or interconnected distribution facilities

1.46 Transmission Provider: The Transmission Provider shall be the Office of the Interconnection for all purposes, provided that the Transmission Owners will have the responsibility for the following specified activities:

- (a) The Office of the Interconnection shall direct the operation and coordinate the maintenance of the Transmission System, except that the Transmission Owners will continue to direct the operation and maintenance of those transmission facilities that are not listed in the PJM Designated Facilities List contained in the PJM Manual on Transmission Operations;
- (b) Each Transmission Owner shall physically operate and maintain all of the facilities that it owns; and
- (c) When studies conducted by the Office of the Interconnection indicate that enhancements or modifications to the Transmission System are necessary, the Transmission Owners shall have the responsibility, in accordance with the applicable terms of the Tariff, Operating Agreement and/or Transmission Owners Agreement or West Transmission Owners Agreement, to construct, own, and finance the needed facilities or enhancements or modifications to facilities.

1.49 Transmission System: The facilities controlled or operated by the Transmission Provider within the PJM Control Area and PJM West Region that are used to provide transmission service under Part II and Part III of the Tariff.

1.49A Transmission Withdrawal Rights: Firm Transmission Withdrawal Rights and Non-Firm Transmission Withdrawal Rights.

APPENDIX 2

SUBPART E - TERMS AND CONDITIONS

From the PJM Tariff accepted for filing by the Commission
as of the effective date of this ISA

51 Commencement, Term Of And Conditions Precedent To Interconnection Service

51.1 Commencement Date. Subject to regulatory acceptance, an Interconnection Service Agreement entered into pursuant to this . Subpart E shall become effective upon its execution by all Interconnection Parties, or, if the agreement is filed unexecuted, upon the date specified by FERC. Interconnection Service under this Subpart shall commence upon the satisfaction of the conditions precedent set forth in Section 51.2 below.

51.2 Conditions Precedent. The following conditions must be satisfied prior to the commencement of Interconnection Service under this Subpart:

- (a) An Interconnection Service Agreement in conformity with Section 36.8 or Section 41.7 of the Tariff among the Transmission Provider, the Interconnection Customer and the Interconnected Transmission Owner for the Customer Facility shall have been accepted for filing by the li'ERC;
- (b) All requirements for Initial Operation as specified in Section 51.4 below shall have been met and Initial Operation of the Customer Facility shall have been completed.
- (c) Interconnection Customer shall be in compliance with all Applicable Technical Requirements and Standards for interconnection under the Tariff (as determined by the Transmission Provider).

51.3 Term. An Interconnection Service Agreement shall remain in full force and effect until it is terminated in accordance with Section 66 of this Subpart E.

51.4 Initial Operation. The following requirements shall be satisfied prior to Initial Operation of the Customer Facility:

- 51.4.1 The construction of all Interconnection Facilities necessary for the interconnection of the Customer Facility has been completed;
- 51.4.2 The Interconnected Transmission Owner has accepted any Interconnection Facilities and/or Merchant Network Upgrades constructed by Interconnection Customer pursuant to Section 83.10 of the Tariff;
- 51.4.3 Interconnection Customer and the Interconnected Transmission Owner have all necessary systems and personnel in place to allow for parallel operation of their respective facilities;
- 51.4.4 Interconnected Transmission Owner has received all applicable documentation for the Interconnection Facilities and/or Merchant Network Upgrades built by the Interconnection Customer, certified as correct, including, but not limited to, marked-up drawings reflecting the as-built condition, pre-operation test reports, and instruction books; and
- 51.4.5 Interconnection Customer shall have received any necessary authorization from Transmission Provider to synchronize with the Transmission System or to energize, as applicable per the determination of Transmission Provider, the Customer Facility and Interconnection Facilities.

51.5 Survival. The Interconnection Service Agreement shall continue in effect after termination to the extent necessary to provide for final billings and payments; to permit the determination and enforcement of liability and indemnification obligations arising from acts or events that occurred while the Interconnection Service Agreement was in effect; and to permit each Interconnection Party to have access to the real property, including but not limited to leased property and easements of the other Interconnection Parties pursuant to Section 66 to disconnect, remove or salvage its own facilities and

equipment.

52 **Interconnection Service**

- 52.1 **Scope of Service.** Interconnection Service shall be provided to the Interconnection Customer at the Point of Interconnection (a), in the case of interconnection of the Customer Facility of a Generation Interconnection Customer, up to the Maximum Facility Output, and (b), in the case of interconnection of the Customer Facility of a Transmission Interconnection Customer, up to the Nominal Rated Capability. The location of the Point of Interconnection shall be mutually agreed by the Interconnected Entities, provided, however, that if the Interconnected Entities are unable to agree on the Point of Interconnection, the Transmission Provider shall determine the Point of Interconnection, provided that Transmission Provider shall not select a Point of Interconnection that would impose excessive costs on either of the Interconnected Entities and shall take material system reliability considerations into account in such selection. Specifications for the Customer Facility and the location of the Point of Interconnection shall be set forth in an appendix to the Interconnection Service Agreement and shall conform to those stated in the Facilities Study.
- 52.2 **Non-Standard Terms.** The standard terms and conditions of this Subpart E shall not apply, to such extent as Transmission Provider determines to be reasonably necessary to accommodate such circumstances, in the event that the Interconnection Customer acquires an ownership interest in facilities which, under the standard terms and conditions of Subpart F, would be part of the Transmission Owner Interconnection Facilities. In such circumstances and to the extent determined by Transmission Provider to be reasonably necessary, non-standard terms and conditions mutually agreed upon by all Interconnection Parties shall apply, subject to FERC and any other necessary regulatory acceptance or approval. In addition, a Generation Interconnection Customer that acquires an ownership interest in such facilities shall become, and shall remain for so long as it retains such interest, a signatory to either the Transmission Owners Agreement or the West Transmission Owners Agreement, as appropriate.
- 52.3 **No Transmission Services.** The execution of an Interconnection Service Agreement does not constitute a request for transmission service, or entitle Interconnection Customer to receive transmission service, under Part II or Part III of the Tariff. Nor does the execution of an Interconnection Service Agreement obligate the Interconnected Transmission Owner or Transmission Provider to procure, supply or deliver to Interconnection Customer or the Customer Facility any energy, capacity, Ancillary Services or Station Power (and any associated distribution services).
- 52.4 **Use of Distribution Facilities.** To the extent that a Generation Interconnection Customer uses distribution facilities for the purpose of delivering energy to the Transmission System, Interconnection Service under this Tariff shall include the construction and/or use of such distribution facilities. In such cases, to such extent as Transmission Provider determines to be reasonably necessary to accommodate such circumstances, the Interconnection Service Agreement may

include non-standard terms and conditions mutually agreed upon by all Interconnection Parties as needed to conform with Applicable Laws and Regulations and Applicable Standards relating to such distribution facilities.

53 Modification Of Facilities

53.1 General. Subject to Applicable Laws and Regulations and to any applicable requirements or conditions of the Tariff and the Operating Agreement, either Interconnected Entity may undertake modifications to its facilities. In the event that an Interconnected Entity plans to undertake a modification that reasonably may be expected upon completion to have a permanent material impact on the other Interconnected Entity's facilities, that Interconnected Entity, in accordance with Good Utility Practice, shall provide the other Interconnection Parties with sufficient information regarding such modification, so that the other Interconnection Parties may evaluate the potential impact of such modification prior to commencement of the work. The Interconnected Entity desiring to perform such modification shall provide the relevant drawings, plans, and specifications to the other Interconnection Parties at least ninety days, or such shorter period to which the Interconnection Parties receiving the information may agree (which agreement shall not unreasonably be withheld, conditioned, or delayed), in advance of the beginning of the work. The Interconnection Customer shall notify Transmission Provider and Interconnected Transmission Owner of the proposed modifications and Transmission Provider shall provide, within sixty days of receipt of the relevant drawings and specifications (or within such other time upon which the Interconnection Parties may agree), an estimate of any modifications to the Transmission System that would be necessary to accommodate the proposed modifications by Interconnection Customer and a good faith estimate of the costs thereof.

53.2 Interconnection Request. This Section 53 of Subpart E shall not apply to any proposed modifications by Interconnection Customer to its facilities for which Interconnection Customer must make an Interconnection Request under the Tariff. In such circumstances, the Interconnection Customer and Transmission Provider shall follow the requirements of Subpart A and/or Subpart B of Part IV of the Tariff.

53.3 Standards. Any additions, modifications, or replacements made to an Interconnected Entity's facilities shall be constructed and operated in accordance with Good Utility Practice, Applicable Standards and Applicable Laws and Regulations.

53.4 Modification Costs. Unless otherwise required by Applicable Laws and Regulations or this Subpart E and, with respect to a Transmission Interconnection Customer, subject to the terms of Section 49A.2 of the Tariff:

- (a) Interconnection Customer shall not be responsible for the costs of any additions, modifications, or replacements that the Interconnected Transmission Owner in its discretion or at the direction of Transmission Provider makes to the Interconnection Facilities or the Transmission System in order to facilitate the interconnection of a third party to the Interconnection Facilities or the Transmission System, or to provide transmission service under the Tariff to a third party.
- (b) Interconnection Customer shall be responsible for the costs of any additions, modifications, or replacements to the Interconnection Facilities or the Transmission System that are required, in accord with Good Utility Practice and/or to maintain compliance with Applicable Laws and Regulations or Applicable Standards, in order to accommodate additions, modifications, or replacements made by Interconnection Customer to the Customer Facility or to the Customer Interconnection Facilities.
- (c) Interconnection Customer shall be responsible for the costs of any additions, modifications, or replacements to the Customer Interconnection Facilities or the Customer Facility that are required, in accord with Good Utility Practice and/or to maintain compliance with Applicable Laws and Regulations or Applicable Standards, in order to accommodate additions, modifications, or replacements that Transmission Provider or the Interconnected Transmission Owner makes to the Transmission System or to the Transmission Owner Interconnection Facilities, but only to the extent that Transmission Provider's or the Interconnected Transmission Owner's changes to the Transmission System or the Transmission Owner Interconnection Facilities are made pursuant to Good Utility Practice and/or to maintain compliance with Applicable Laws and Regulations or Applicable Standards.

54 Operations

54.1 General. Each Interconnected Entity shall operate, or shall cause operation of, its facilities in a safe and reliable manner in accord with (i) the terms of this Subpart; (ii) Applicable Standards; (iii) applicable rules, procedures and protocols set forth in the Tariff and the Operating Agreement, as any or all may be amended from time to time; (iv) Applicable Laws and Regulations, and (v) Good Utility Practice.

54.2 Operation of Merchant Network Upgrades. Unless otherwise provided in the Interconnection Service Agreement, the Interconnected Transmission Owner that owns Transmission System facilities to which any Merchant Network Upgrades are connected shall operate such Merchant Network Upgrades (a) on behalf and at the expense of the Interconnection Customer that constructed or caused construction of the pertinent Merchant Network Upgrades and (b) in accordance with this Subpart E and with an agreement between the Interconnected Transmission Owner and the Interconnection Customer regarding such operation.

54.3 Interconnection Customer Obligations. Interconnection Customer shall obtain Transmission Provider's approval prior to either synchronizing with the Transmission System or energizing, as applicable per the determination of Transmission Provider, the Customer Facility or, except in an Emergency Condition, disconnecting the Customer Facility from the Transmission System, and shall coordinate such synchronizations, energizations, and disconnections with the Interconnected Transmission Owner.

54.4 [Reserved]

54.5 Permits and Rights-of-Way. Each Interconnected Entity at its own expense shall maintain in full force and effect all permits, licenses, rights-of-way and other authorizations as may be required to maintain the Customer Facility and the Interconnection Facilities that the entity owns, operates and maintains and, upon reasonable request of the other Interconnected Entity, shall provide copies of such permits, licenses, rights-of-way and other authorizations at its own expense to the requesting party.

54.6 No Ancillary Services. Except as provided in Section 54.7, nothing in this Subpart E is intended to obligate the Interconnection Customer to supply Ancillary Services to either Transmission Provider or the Interconnected Transmission Owner.

54.7 Reactive Power.

54.7.1 Reactive Power Design Criteria. Except as Transmission Provider determines otherwise for small generation resources (as described in the Preamble to Subpart G of Part IV of the Tariff), a Generation Interconnection Customer shall design its Customer Facility to maintain a composite power delivery at continuous rated power output at the generator's terminals at a power factor of at least 0.95 leading to 0.90 lagging. Any different reactive power design criteria that Transmission Provider determines to be appropriate for a small generation resource shall be stated as a non-standard term of the Interconnection Service Agreement. A Transmission Interconnection Customer interconnecting Merchant D.C. Transmission Facilities shall design its Customer Facility to maintain a composite power delivery over the entire operating range of the facility at a power factor of at least 0.95 leading and 0.95 lagging at the Point(s) of Interconnection.

54.7.2 Obligation to Supply Reactive Power. Interconnection Customer agrees, as and when so directed by Transmission Provider or when so directed by the Interconnected Transmission Owner acting on behalf or at the direction of Transmission Provider, to operate the Customer Facility to produce reactive power within the design limitations of the Customer Facility pursuant to voltage schedules, reactive power schedules or power factor schedules established by Transmission Provider or, as appropriate, the Interconnected Transmission Owner. Transmission Provider shall maintain oversight over such schedules to ensure that all sources of reactive power in the PJM Control Area or the PJM West Region, as

applicable, are treated in an equitable and not unduly discriminatory manner. Interconnection Customer agrees that Transmission Provider and the Interconnected Transmission Owner, acting on behalf or at the direction of Transmission Provider, may make changes to the schedules that they respectively establish as necessary to maintain the reliability of the Transmission System.

54.7.3 Deviations from Schedules. In the event that operation of the Customer Facility of an Interconnection Customer causes the Transmission System or the Interconnected Transmission Owner's facilities to deviate from appropriate voltage schedules and/or reactive power schedules as specified by Transmission Provider or the Interconnected Transmission Owner's operations control center (acting on behalf or at the direction of Transmission Provider), or that otherwise is inconsistent with Good Utility Practice and results in an unreasonable deterioration of the quality of electric service to other customers of Transmission Provider or the Interconnected Transmission Owner, the Interconnection Customer shall, upon discovery of the problem, or upon notice from Transmission Provider or the Interconnected Transmission Owner, acting on behalf or at the direction of Transmission Provider, take whatever steps are reasonably necessary to alleviate the situation at its expense, in accord with Good Utility Practice and within the reactive capability of the Customer Facility. In the event that the Interconnection Customer does not alleviate the situation within a reasonable period of time following Transmission Provider's or the Interconnected Transmission Owner's notice thereof, the Interconnected Transmission Owner, with Transmission Provider's approval, upon notice to the Interconnection Customer and at the Interconnection Customer's expense, may take appropriate action, including installation on the Transmission System of power factor correction or other equipment, as is reasonably required, consistent with Good Utility Practice, to remedy the situation cited in Transmission Provider's or the Interconnected Transmission Owner's notice to the Interconnection Customer under this section.

54.7.4 Payment for Reactive Power. Any payments to the Interconnection Customer for reactive power shall be in accordance with Schedule 2 of the Tariff.

54.8 [Reserved]

54.9 Protection and System Quality.

54.9.1 System Protection. Interconnection Customer shall, at its expense, install, operate and maintain such System Protection Facilities as may be required in connection with operation of the Customer Facility and the Customer Interconnection Facilities consistent with Applicable Technical Requirements and Standards. Interconnected Transmission Owner shall install any System Protection Facilities that may be required, as determined by Transmission Provider, on the Transmission Owner Interconnection Facilities or the Transmission System in connection with

the operation of the Customer Facility and the Customer Interconnection Facilities. Responsibility for the cost of any System Protection Facilities required on the Transmission Owner Interconnection Facilities or the Transmission System shall be allocated as provided in Section 37 or Section 42 of the Tariff.

54.9.2 Power Quality. The Customer Facility and Customer Interconnection Facilities shall not cause excessive deviations from the power quality criteria set forth in the Applicable Technical Requirements and Standards.

54.10 [Reserved]

54.11 Access Rights. Each Interconnected Entity shall provide the other Interconnected Entity access to areas under its control as reasonably necessary to permit the other Interconnected Entity to perform its obligations under this Subpart, including operation and maintenance obligations. An Interconnected Entity that obtains such access shall comply with all safety rules applicable to the area to which access is obtained. Each Interconnected Entity agrees to inform the other Interconnected Entity's representatives of safety rules applicable to an area.

54.12 Switching and Tagging Rules. The Interconnected Entities shall comply with applicable Switching and Tagging Rules as stated in the applicable appendix to the Interconnection Service Agreement in obtaining clearances for work or for switching operations on equipment. Such Switching and Tagging Rules shall be developed in accordance with OSHA standards codified at 29 CFR Part 1910, or successor standards. Each Interconnected Entity shall provide the other Interconnected Entity a copy of its Switching and Tagging Rules that are applicable to the other Interconnected Entity's activities.

54.13 Communications and Data Protocol. The Interconnected Entities shall comply with any communications and data protocol that the Transmission Provider may establish.

54.14 Nuclear Generating Facilities. In the event that the Customer Facility is a nuclear generating facility, the Interconnection Parties shall agree to such nonstandard terms and conditions as are reasonably necessary to accommodate the Interconnection Customer's satisfaction of Nuclear Regulatory Commission requirements relating to the safety and reliability of operations of such facilities.

55 Maintenance

55.1 General. Each Interconnected Entity shall maintain, or shall cause the maintenance of, its facilities in a safe and reliable manner in accord with (i) the terms of this Subpart; (ii) Applicable Standards; (iii) applicable rules, procedures and protocols set forth in the Tariff and the Operating Agreement, as any or all may be amended from time to time; (iv) Applicable Laws and Regulations, and (v) Good Utility Practice.

55.2 Maintenance of Merchant Network Upgrades. Unless otherwise provided in the Interconnection Service Agreement, the Interconnected Transmission Owner that owns Transmission System facilities to which any Merchant Network Upgrades are connected shall maintain such Merchant Network Upgrades (a) on behalf and at the expense of the Interconnection Customer that constructed or caused construction of the pertinent Merchant Network Upgrades and (b) in accordance with this Subpart E and with an agreement between the Interconnected Transmission Owner and the Interconnection Customer regarding such maintenance.

55.3 Outage Authority and Coordination.

55.3.1 Coordination. The Interconnection Parties agree to confer regularly to coordinate the planning, scheduling and performance of preventive and corrective maintenance on the Customer Facility, the Customer Interconnection Facilities and any Attachment Facilities owned by the Interconnected Transmission Owner.

55.3.2 Authority. Each Interconnected Entity may, in accordance with Good Utility Practice, remove from service its facilities that may affect the other Interconnected Entity's facilities in order to perform maintenance or testing or to install or replace equipment. Except in the event of an Emergency Condition, the Interconnection Customer proposing to remove such facilities from service shall provide prior notice of such activities to the Transmission Provider and the Interconnected Transmission Owner, and the Interconnected Entities shall coordinate all scheduling of planned facility outages with Transmission Provider, in accordance with applicable sections of the Operating Agreement, the PJM Manuals and any other applicable operating guidelines or directives of the Transmission Provider. Subject to the foregoing, the Interconnected Entity scheduling a facility outage shall use Reasonable Efforts to coordinate such outage with the other Interconnected Entity's scheduled outages.

55.3.3 Outages Required for Maintenance. Subject to any necessary approval by Transmission Provider, each Interconnected Entity shall provide necessary equipment outages to allow the other Interconnected Entity to perform periodic maintenance, repair or replacement of its facilities and such outages shall be provided at mutually agreeable times, unless conditions arise which an Interconnected Entity believes, in accordance with Good Utility Practice, may endanger persons or property.

55.3.4 Rescheduling of Planned Outages. To the extent so provided by the Tariff, the Operating Agreement, and the PJM Manuals, an Interconnected Entity may seek compensation from Transmission Provider for any costs related to rejection by Transmission Provider of a request of such Interconnected Entity for a planned maintenance outage.

55.3.5 Outage Restoration. If an outage on an Interconnected Entity's facilities adversely affects the other Interconnected Entity's facilities, the Interconnected Entity that owns or controls the facility that is out of service shall use Reasonable Efforts to restore the facility to service promptly.

55.4 Inspections and Testing. Each Interconnected Entity shall perform routine inspection and testing of its facilities and equipment in accordance with Good Utility Practice as may be necessary to ensure the continued interconnection of the Customer Facility with the Transmission System in a safe and reliable manner. Each Interconnected Entity shall have the right, upon advance written notice, to request reasonable additional testing of an Interconnected Entity's facilities for good cause, as may be in accordance with Good Utility Practice.

55.5 Right to Observe Testing. Each Interconnected Entity shall notify the other Interconnected Entity in advance of its performance of tests of its portion of the Interconnection Facilities or of any Merchant Network Upgrades. The other Interconnected Entity shall, at its own expense, have the right to observe such testing.

55.6 Secondary Systems. Each Interconnected Entity agrees to cooperate with the other in the inspection, maintenance, and testing of those Secondary Systems directly affecting the operation of an Interconnected Entity's facilities and equipment which may reasonably be expected to affect the other Interconnected Entity's facilities. Each Interconnected Entity shall provide advance notice to the other Interconnected Entity before undertaking any work on such equipment, especially in electrical circuits involving circuit breaker trip and close contacts, current transformers, or potential transformers.

55.7 Access Rights. Each Interconnected Entity shall provide the other Interconnected Entity access to areas under its control as reasonably necessary to permit the other Interconnected Entity to perform its obligations under this Subpart, including operation and maintenance obligations. An Interconnected Entity that obtains such access shall comply with all safety rules applicable to the area to which access is obtained. Each Interconnected Entity agrees to inform the other Interconnected Entity's representatives of safety rules applicable to an area.

55.8 Observation of Deficiencies. If an Interconnection Party observes any Abnormal Condition on, or becomes aware of a lack of scheduled maintenance and testing with respect to, an Interconnection Party's facilities and equipment that might reasonably be expected to adversely affect the observing Interconnection Party's facilities and equipment, the observing Interconnection Party shall provide prompt notice under the circumstances to the appropriate Interconnection Party, and such Interconnection Party shall consider such notice in accordance with Good Utility Practice. Any Interconnection Party's review, inspection, and approval related to the other Interconnection Party's facilities and equipment shall be limited to the purpose of assessing the safety, reliability, protection and control of the Transmission System and shall not be construed as confirming or endorsing the design of such facilities and equipment, or as a warranty of any type, including

safety, durability or reliability thereof. Notwithstanding the foregoing, the observing Interconnection Party shall have no liability whatsoever for failure to give a deficiency notice to the other Interconnection Party and the Interconnected Entity that owns the relevant Interconnection Facilities shall remain fully liable for its failure to determine and correct deficiencies and defects in its facilities and equipment.

56 Emergency Operations

56.1 Obligations. Subject to Applicable Laws and Regulations, each Interconnection Party shall comply with the Emergency Condition procedures of NERC, the Applicable Reliability Council, Transmission Provider, the Interconnected Transmission Owner and Interconnection Customer.

56.2 Notice. Each Interconnection Party shall notify the other parties promptly when it becomes aware of an Emergency Condition that may reasonably be expected to affect operation of the Customer Facility, the Customer Interconnection Facilities, the Transmission Owner Interconnection Facilities, or the Transmission System. To the extent information is known, the notification shall describe the Emergency Condition, the extent of the damage or deficiency, the expected effect on the facilities and/or operation thereof, its anticipated duration and the corrective action taken and/or to be taken. The initial notice shall be followed as soon as practicable with written notice.

56.3 Immediate Action. An Interconnection Party becoming aware of an Emergency Condition may take such action, including disconnection of the Customer Facility from the Transmission System, as is reasonable and necessary in accord with Good Utility Practice (i) to prevent, avoid, or mitigate injury or danger to, or loss of, life or property; (ii) to preserve the reliability of, in the case of Interconnection Customer, the Customer Facility, or, in the case of Transmission Provider or the Interconnected Transmission Owner, the Transmission System and interconnected sub-transmission and distribution facilities; or (iii) to expedite restoration of service. Unless, in Interconnection Customer's reasonable judgment, immediate action is required to prevent imminent loss of life or property, Interconnection Customer shall obtain the consent of Transmission Provider and the Interconnected Transmission Owner prior to performing any manual switching operations at the Customer Facility or the Generation Interconnection Facilities. Each Interconnection Party shall use Reasonable Efforts to minimize the effect of its actions during an Emergency Condition on the facilities and operations of the other Interconnection Parties.

56.4 Record-Keeping Obligations. Each Interconnection Party shall keep and maintain records of actions taken during an Emergency Condition that may reasonably be expected to affect the other parties' facilities and make such records available for audit in accordance with Section 69.3.

57 Safety

- 57.1 General.** Each Interconnected Entity shall perform all work under this Subpart that may reasonably be expected to affect the other Interconnected Entity in accordance with Good Utility Practice and all Applicable Laws and Regulations pertaining to the safety of persons or property. An Interconnected Entity performing work within the boundaries of the other Interconnected Entity's facilities must abide by the safety rules applicable to the site. Each party agrees to inform the other party's representatives of applicable safety rules that must be obeyed on the premises.
- 57.2 Environmental Releases.** Each Interconnected Entity shall notify the other Interconnection Parties, first orally and promptly thereafter in writing, of the release of any Hazardous Substances, any asbestos or lead abatement activities, or any type of remediation activities, related to the Customer Facility or the Interconnection Facilities, any of which may reasonably be expected to affect one or both of the other parties. The notifying party shall (i) provide the notice as soon as possible; (ii) make a good faith effort to provide the notice within twenty-four (24) hours after the party becomes aware of the occurrence; and (iii) promptly furnish to the other parties copies of any publicly available reports filed with any governmental agencies addressing such events.

58 Metering

- 58.1 General.** Interconnection Customer shall have the right to install, own, operate, test and maintain the necessary Metering Equipment. In the event that Interconnection Customer exercises this option, the Interconnected Transmission Owner shall have the right to install its own check meter(s), at its own expense, at or near the location of the Metering Equipment. If both Interconnection Customer and Interconnected Transmission Owner install meters, the meter installed by the Interconnection Customer shall control unless it is determined by testing to be inaccurate. If the Interconnection Customer does not exercise the option provided by the first sentence of this section, the Interconnected Transmission Owner shall have the option to install, own, operate, test and maintain all necessary Metering Equipment at Interconnection Customer's expense. If the Interconnected Transmission Owner does not exercise this option, the Interconnection Customer shall install, own, operate, test and maintain all necessary Metering Equipment. Transmission Provider shall determine the location where the Metering Equipment shall be installed, after consulting with Interconnection Customer and the Interconnected Transmission Owner. All Metering Equipment shall be tested prior to any operation of the Customer Facility. Power flows to and from the Customer Facility shall be compensated to the Point of Interconnection, or, upon the mutual agreement of the Interconnected Transmission Owner and the Interconnection Customer, to another location.
- 58.2 Standards.** All Metering Equipment installed pursuant to this Subpart shall be revenue quality Metering Equipment and shall satisfy applicable ANSI standards and Transmission Provider's metering standards and requirements. Nothing in this Subpart precludes the use of Metering Equipment for any retail services of the Interconnected Transmission Owner provided, however, that in such circumstances
Applicable Laws and Regulations shall control.

58.3 Testing of Metering Equipment. The Interconnected Entity that, pursuant to Section 58.1, owns the Metering Equipment shall operate, maintain, inspect and test all Metering Equipment upon installation and at least once every two years thereafter. Upon reasonable request by the other Interconnected Entity, the owner of the Metering Equipment shall inspect or test the Metering Equipment more frequently than every two years, but in no event more frequently than three times in any 24-month period. The owner of the Metering Equipment shall give reasonable notice to the Interconnection Parties of the time when any inspection or test of the owner's Metering Equipment shall take place, and the other parties may have representatives present at the test or inspection. If Metering Equipment is found to be inaccurate or defective, it shall be adjusted, repaired or replaced in order to provide accurate metering. Where the Interconnected Transmission Owner owns the Metering Equipment, the expense of such adjustment, repair or replacement shall be borne by the Interconnection Customer, except that the Interconnection Customer shall not be responsible for such expenses where the inaccuracy or defect is caused by the Interconnected Transmission Owner. If Metering Equipment fails to register, or if the measurement made by Metering Equipment during a test varies by more than one percent from the measurement made by the standard meter used in the test, the owner of the Metering Equipment shall inform Transmission Provider, and the Transmission Provider shall inform the other Interconnected Entity, of the need to correct all measurements made by the inaccurate meter for the period during which the inaccurate measurements were made, if the period can be determined. If the period of inaccurate measurement cannot be determined, the correction shall be for the period immediately preceding the test of the Metering Equipment that is equal to one-half of the time from the date of the last previous test of the Metering Equipment, provided that the period subject to correction shall not exceed nine (9) months.

58.4 Metering Data. At Interconnection Customer's expense, the metered data shall be telemetered to a location designated by Transmission Provider, to a location designated by the Interconnected Transmission Owner, and to a location designated by Interconnection Customer. Data from the Metering Equipment at the Point of Interconnection shall be used, under normal operating conditions, as the official measurement of the amount of energy delivered from or to the Customer Facility to the Point of Interconnection, provided that the Transmission Provider's rules applicable to Station Power shall control with respect to a Generation Interconnection Customer's consumption, of Station Power.

58.5 Communications.

58.5.1 Interconnection Customer Obligations. Interconnection Customer shall install and maintain satisfactory operating communications with Transmission Provider's system dispatcher or its other designated representative and with the Interconnected Transmission Owner. Interconnection Customer shall provide standard voice line, dedicated voice line and facsimile communications at its Customer Facility control room through use of the public telephone system. Interconnection Customer also shall provide and maintain backup communication links with both Transmission Provider and Interconnected Transmission Owner

for use during abnormal conditions as specified by Transmission Provider and Interconnected Transmission Owner, respectively. Interconnection Customer further shall provide the dedicated data circuit(s) necessary to provide Interconnection Customer data to the Transmission Provider and Interconnected Transmission Owner as necessary to conform with Applicable Technical Requirements and Standards.

58.5.2 **Remote Terminal Unit.** Prior to any operation of the Customer Facility, a remote terminal unit, or equivalent data collection and transfer equipment acceptable to the Interconnection Parties, shall be installed by Interconnection Customer, or by the Interconnected Transmission Owner at Interconnection Customer's expense, to gather accumulated and instantaneous data to be telemetered to the location(s) designated by Transmission Provider and Interconnected Transmission Owner through use of a dedicated point-to-point data circuit(s) as indicated in Section 58.5.1. Instantaneous, bi-directional real power and, with respect to a Generation Interconnection Customer's Customer Facility, reactive power flow information, must be telemetered directly to the location(s) specified by Transmission Provider and the Interconnected Transmission Owner.

59 Force Majeure

59.1 Notice. An Interconnection Party that is unable to carry out an obligation imposed on it by this Subpart due to Force Majeure shall notify the other parties in writing or by telephone within a reasonable time after the occurrence of the cause relied on.

59.2 Duration of Force Majeure. An Interconnection Party shall not be responsible, or considered to be in Breach or Default under this Subpart, for any nonperformance, any interruption or failure of service, deficiency in the quality or quantity of service, or any other failure to perform any obligation hereunder to the extent that such failure or deficiency is due to Force Majeure. An Interconnection Party shall be excused from whatever performance is affected only for the duration of the Force Majeure and while the Interconnection- Party exercises Reasonable Efforts to alleviate such situation. As soon as the non-performing Interconnection Party is able to resume performance of its obligations excused because of the occurrence of Force Majeure, such Interconnection Party shall resume performance and give prompt notice thereof to the other parties.

59.3 Obligation to Make Payments. Any Interconnection Party's obligation to make payments for services shall not be suspended by Force Majeure.

60 Charges

60.1 Specified Charges. If and to the extent required by the Interconnected Transmission Owner, Interconnection Customer shall pay one or more of the types of charges described in this section to compensate the Interconnected Transmission Owner for costs incurred in performing certain of its obligations under this Subpart. All such charges shall be stated in an attachment to the

Interconnection Service Agreement. Interconnected Transmission Owner shall provide Transmission Provider and Interconnection Customer with appropriate cost data, schedules and/or written testimony in support of any charges under this section in such manner and at such time as to allow Transmission Provider to include such materials in its filing of the Interconnection Service Agreement with the FERC. Transmission Provider will deliver a copy of such filing to Interconnection Customer. Permissible charges under this section may include:

- (a) Administration Charge-Any such charge may recover only the costs and expenses incurred by the Interconnected Transmission Owner in connection with administrative obligations such as the preparation of bills, the processing of Customer Facility-specific data on energy delivered at the Point of Interconnection and costs incurred in similar types of administrative processes related to Interconnection Customer's Interconnection Service. An Administration Charge shall not be permitted to the extent that the Interconnected Transmission Owner's other charges to the Interconnection Customer under the same Interconnection Service Agreement include an allocation of Interconnected Transmission Owner's administrative and general expenses and/or other corporate overhead costs.
- (b) Metering Charge - Any such charge may recover only the Interconnected Transmission Owner's costs and expenses associated with operation, maintenance, inspection, testing, and carrying or capital replacement charges for any Metering Equipment that is owned by the Interconnected Transmission Owner.
- (c) Telemetering Charge - Any such charge may recover only the Interconnected Transmission Owner's costs and expenses associated with operation, maintenance, inspection, testing, and carrying or capital replacement charges for any telemetering equipment that is owned by the Interconnected Transmission Owner and that is used exclusively in conjunction with Interconnection Service for the Interconnection Customer.
- (d) Customer Facility Operations and Maintenance Charge - Any such charge may recover only the Interconnected Transmission Owner's costs and expenses associated with operation, maintenance, inspection, testing, modifications, taxes and carrying or capital replacement charges for Attachment Facilities related to the Interconnection Customer's Interconnection Service and that are owned by the Interconnected Transmission Owner, provided that

any such charge shall exclude costs and expenses associated with Transmission Owner Interconnection Facilities owned by the Interconnected Transmission Owner that are radial line facilities that serve load in addition to an Interconnection Customer; and

(i)

except as otherwise provided by Applicable Laws and Regulations, any such charge may include only an allocated share, derived in accordance with the allocations contained in the Facilities Study,

of costs and expenses associated with Transmission Owner Interconnection Facilities owned by the Interconnected Transmission Owner that are radial line facilities that serve more than one Interconnection Customer.

At the discretion of the affected Interconnected Entities, a Customer Facility Operations and Maintenance Charge authorized under this section may apply on a per-incident basis or on a monthly or other periodic basis.

- (e) Other Charges - Any other charges applicable to the Interconnection Customer, as mutually agreed upon by the Interconnection Customer and the Interconnected Transmission Owner and as accepted by the FERC as part of an Interconnection Service Agreement.

60.2 FERC Filings. To the extent required by law or regulation, each Interconnection Party shall seek FERC acceptance or approval of its respective charges or the methodology for the calculation of such charges.

61 Billing And Payments

61.1 General. Except as, and to the extent, otherwise provided in the Interconnection Service Agreement, billing and payment of any charges applicable to Interconnection Service under this Subpart E shall be in accordance with Section 7 of the Tariff. The Interconnected Transmission Owner shall provide Transmission Provider with all necessary information and supporting data that Transmission Provider may reasonably require to administer billing for and payment of applicable charges under this Subpart E. Transmission Provider shall remit to the Interconnected Transmission Owner revenues received in payment of Interconnected Transmission Owner's charges to Interconnection Customer under this Subpart E upon Transmission Provider's receipt of such revenues. At Transmission Provider's reasonable discretion, charges to Interconnection Customer and remittances to Interconnected Transmission Owner under this Subpart E may be netted against other amounts owed by or to such parties under the Tariff.

61.2 Billing Disputes. In the event of a billing dispute between Transmission Provider and Interconnection Customer, Transmission Provider shall continue to provide interconnection service under this Subpart of the Tariff as long as Interconnection Customer (i) continues to make all payments not in dispute, and (ii) pays to Transmission Provider or into an independent escrow account the portion of the invoice in dispute, pending resolution of such dispute. If Interconnection Customer fails to meet these two requirements for continuation of service, then Transmission Provider shall so inform the Interconnection Parties and may provide notice to Interconnection Customer of a Breach pursuant to Section 65 of the Tariff. Within thirty days after the resolution of the dispute, the Interconnection Party that owes money to the other Interconnection Party shall pay the amount due with interest calculated in accord with Section 61.4.

61.3 No Waiver. Payment of an invoice shall not relieve Interconnection Customer from any other responsibilities or obligations it has under this Subpart, nor shall such payment constitute a waiver of any claims arising hereunder.

61.4 Interest. Interest on any unpaid amounts shall be calculated in accordance with the methodology specified for interest on refunds in the FERC's regulations at 18 C.F.R. § 35.19a(a)(2)(iii). Interest on delinquent amounts shall be calculated from the due date of the bill to the date of payment.

62 Assignment

62.1 Assignment with Prior Consent. Except as provided in Section 62.2, no Interconnection Party shall assign its rights or delegate its duties, or any part of such rights or duties, under the Interconnection Service Agreement without the written consent of the other Interconnection Parties, which consent shall not be unreasonably withheld, conditioned, or delayed. Any such assignment, or delegation made without such written consent shall be null and void. An Interconnection Party may make an assignment in connection with the sale, merger, or transfer of a substantial portion or all of its properties including the Interconnection Facilities which it owns, so long as the assignee in such a sale, merger, or transfer assumes in writing all rights, duties and obligations arising under this Subpart and the Interconnection Service Agreement. In addition, the Interconnected Transmission Owner shall be entitled, subject to Applicable Laws and Regulations, to assign the Interconnection Service Agreement to any Affiliate or successor that owns and operates all or a substantial portion of the Interconnected Transmission Owner's transmission facilities.

62.2 Assignment Without Prior Consent.

62.2.1 Assignment to Owners. Interconnection Customer may assign the Interconnection Service Agreement without the Interconnected Transmission Owner's or Transmission Provider's prior consent to any Affiliate or person that purchases or otherwise acquires, directly or indirectly, all or substantially all of the Customer Facility and the Customer Interconnection Facilities, provided that prior to the effective date of any such assignment, the assignee shall demonstrate that, as of the effective date of the assignment, the assignee has the technical and operational competence to comply with the requirements of this Subpart and assumes in a writing provided to the Interconnected Transmission Owner and Transmission Provider all rights, duties, and obligations of Interconnection Customer arising under this Subpart. However, any assignment described herein shall not relieve or discharge the Interconnection Customer from any of its obligations hereunder absent the written consent of the Transmission Provider, such consent not to be unreasonably withheld, conditioned or delayed.

62.2.2 Assignment to Lenders. Interconnection Customer may, without the consent of the Transmission Provider or the Interconnected Transmission Owner, assign the Interconnection Service Agreement to any Project Finance Entity(ies), provided that such assignment does not alter or diminish Interconnection Customer's duties and obligations under this

Subpart or the Interconnection Service Agreement. If Interconnection Customer provides the Interconnected Transmission Owner with notice of an assignment to any Project Finance Entity(ies) and identifies such Project Finance Entities as contacts for notice purposes pursuant to Section 71 of this Subpart, the Transmission Provider or Interconnected Transmission Owner shall provide notice and reasonable opportunity for such entity(ies) to cure any Breach under this Subpart in accordance with this Subpart. Transmission Provider or Interconnected Transmission Owner shall, if requested by such lenders, provide such customary and reasonable documents, including consents to assignment, as maybe reasonably requested with respect to the assignment and status of the Interconnection Service Agreement, provided that such documents do not alter or diminish the rights of the Transmission Provider or Interconnected Transmission Owner under this Subpart, except with respect to providing notice of Breach to a Project Finance Entity. Upon presentation of the Transmission Provider and/or the Interconnected Transmission Owner's invoice therefor, Interconnection Customer shall pay the Transmission Provider and/or the Interconnected Transmission Owner's reasonable documented cost of providing such documents and certificates. Any assignment described herein shall not relieve or discharge the Interconnection Customer from any of its obligations hereunder absent the written consent of the Interconnected Transmission Owner and Transmission Provider.

62.3 Successors and Assigns. This Subpart and all of its provisions are binding upon, and inure to the benefit of, the Interconnection Parties and their respective successors and permitted assigns.

63 Insurance

63.1 Required Coverages: Each Interconnected Entity shall maintain insurance as described in paragraphs A through E below. All insurance shall be procured from insurance companies rated "A-" or better by AM Best and authorized to do business in a state or states in which the Interconnection Facilities are located. Failure to maintain required insurance shall be a Breach of the Interconnection Service Agreement.

- A. Workers Compensation insurance with statutory limits, as required by the state and/or jurisdiction in which the work is to be performed, and employer's liability insurance with limits of not less than one million dollars (\$1,000,000.00).
- B. Commercial General Liability Insurance including coverage for premises, contractual liability, products/completed operations, personal injury, independent contractors, broad form property damage coverage and coverage for the explosion, collapse and underground hazard (XCU), with minimum limits of one million dollars (\$1,000,000.00) per occurrence for bodily injury and property damage, two million dollars (\$2,000,000.00) per occurrence for products/completed operations and two million dollars (\$2,000,000.00) in the general aggregate.

- C. Automobile Liability Insurance for owned, non-owned, and hired vehicles used in performing services under this Subpart with minimum limits of not less than one million dollars (\$1,000,000.00) per occurrence for bodily injury and property damage.
- D. Excess/Umbrella Liability Insurance with a limit of liability of not less than twenty million dollars (\$20,000,000.00) per occurrence. These limits apply in excess of the employer's liability, commercial general liability and automobile liability coverages described above.
- E. Professional Liability Insurance providing errors, omissions and/or malpractice coverage in the amount of five million (\$5,000,000) per occurrence/aggregate with an extended reporting period of at least one year. Coverage shall be provided for the Interconnected Entity's duties, responsibilities and performance outlined in this subpart, the Interconnection Service Agreement, and if applicable, the Construction Service Agreement.

63.2 Additional Insureds: The Commercial General Liability, Automobile Liability and Excess/Umbrella Liability policies procured by each Interconnected Entity (the "Insuring Interconnected Entity") shall include each other Interconnection Party (the "Insured Interconnection Party"), and its respective officers, agents and employees as additional insureds, providing all standard coverages and covering liability of the Insured Interconnection Party arising out of bodily injury and/or property damage (including loss of use) in any way connected with the operations, performance, or lack of performance under this Subpart and/or the Interconnection Service Agreement.

63.3 Other Required Terms: The above-mentioned insurance policies (except workers' compensation) shall provide the following:

- A. Be primary to any other insurance carried by the Insured Interconnection Party.
- B. Contain standard cross-liability provisions.
- C. Provide for a waiver of all rights of subrogation which the Insuring Interconnected Entity's insurance carrier might exercise against the Insured Interconnection Party.

63.4 Self-Insurance. At its option, either Interconnected Entity may, with adequate credit assurance in conformance with standard electric industry practices provided to the other Interconnected Entity and Transmission Provider, self-insure all or part of its insurance obligations under this Subpart. An Interconnected Entity's election to self-insure shall not in any manner result in a reduction of rights and/or benefits otherwise available to the other Interconnected Entity through fonnal insurance policies and endorsements customary in the electric utility industry.

63.5 Notices; Certificates of **Insurance**. All policies of insurance shall provide for thirty days prior written notice of cancellation or material adverse change. Each Interconnected Entity shall provide the other with certificates of insurance prior to Initial Operation of the Customer Facility and thereafter at such time intervals as they shall mutually agree upon, provided that such interval shall not be less than one year. All certificates of insurance shall indicate that the certificate holder is included as an additional insured under the Commercial General Liability, Automobile liability and Excess/Umbrella liability coverages, and that this insurance is primary with a waiver of subrogation included.

63.6 Subcontractor Insurance: In accord with Good Utility Practice, each Interconnected Entity shall require each of its subcontractors to maintain and provide evidence of insurance coverage of types, and in amounts, commensurate with the risks associated with the services [provided by](#) the subcontractor. Bonding of contractors or subcontractors shall be at the hiring Interconnected Entity's discretion, but regardless of bonding, the hiring principal shall be responsible for the performance or non-performance of any contractor or subcontractor it hires.

64 Indemnity

64.1 Indemnity. Each Interconnection Party shall indemnify and hold harmless the other Interconnection Parties, and the other Interconnection Parties' officers, shareholders, stakeholders, members, managers, representatives, directors, agents and employees, and Affiliates, from and against any and all loss, liability, damage, cost or expense to third parties, including damage and liability for bodily injury to or death of persons, or damage to property or persons (including reasonable attorneys' fees and expenses, litigation costs, consultant fees, investigation fees, sums paid in settlements of claims, penalties or fines imposed under Applicable Laws and Regulations, and any such fees and expenses incurred in enforcing this indemnity or collecting any sums due hereunder) (collectively, "**Loss**") to the extent arising out of, in connection with, or resulting from (i) the indemnifying Interconnection Party's breach of any of the representations or warranties made in, or failure of the indemnifying Interconnection Party or any of its subcontractors to perform any of its obligations under, this Subpart and /or the Interconnection Service Agreement, or (ii) the negligence or willful misconduct of the indemnifying Interconnection Party or its contractors; provided, however, that no Interconnection Party shall have any indemnification obligations under this Section 64.1 in respect of any Loss to the extent the Loss results from the negligence or willful misconduct of the Interconnection Party seeking indemnity.

64.2 Indemnity Procedures. Promptly after receipt by a Person entitled to indemnity ("Indemnified Person") of any claim or notice of the commencement of any action or administrative or legal proceeding or investigation as to which the indemnity provided for in Section 64.1 may apply, the Indemnified Person shall notify the indemnifying Interconnection Party of such fact. Any failure of or delay in such notification shall not affect an Interconnection Party's indemnification obligation unless such failure or delay is materially prejudicial to the indemnifying Interconnection Party. The Indemnified Person shall cooperate with the indemnifying Interconnection Party with respect to the matter for which indemnification is claimed. The indemnifying Interconnection Party shall have the

right to assume the defense thereof with counsel designated by such indemnifying Interconnection Party and reasonably satisfactory to the Indemnified Person. If the defendants in any such action include one or more Indemnified Persons and the indemnifying Interconnection Party and if the Indemnified Person reasonably concludes that there may be legal defenses available to it and/or other Indemnified Persons which are different from or additional to those available to the indemnifying Interconnection Party, the Indemnified Person shall have the right to select separate counsel to assert such legal defenses and to otherwise participate in the defense of such action on its own behalf. In such instances, the indemnifying Interconnection Party shall only be required to pay the fees and expenses of one additional attorney to represent an Indemnified Person or Indemnified Persons having such differing or additional legal defenses. The Indemnified Person shall be entitled, at its expense, to participate in any action, suit or proceeding, the defense of which has been assumed by the indemnifying Interconnection Party. Notwithstanding the foregoing, the indemnifying Interconnection Party (i) shall not be entitled to assume and control the defense of any such action, suit or proceedings if and to the extent that, in the opinion of the Indemnified Person and its counsel, such action, suit or proceeding involves the potential imposition of criminal liability on the Indemnified Person, or there exists a conflict or adversity of interest between the Indemnified Person and the indemnifying Interconnection Party, in such event the indemnifying Interconnection Party shall pay the reasonable expenses of the Indemnified Person, and (ii) shall not settle or consent to the entry of any judgment in any action, suit or proceeding without the consent of the Indemnified Person, which shall not be unreasonably withheld, conditioned or delayed.

64.3 Indemnified Person. If an Indemnified Person is entitled to indemnification under this Section 64 as a result of a claim by a third party, and the indemnifying Interconnection Party fails, after notice and reasonable opportunity to proceed under Section 64.2, to assume the defense of such claim, such Indemnified Person may at the expense of the indemnifying Interconnection Party contest, settle or consent to the entry of any judgment with respect to, or pay in full, such claim.

64.4 Amount Owing. If an indemnifying Interconnection Party is obligated to indemnify and hold any Indemnified Person harmless under this Section 64, the amount owing to the Indemnified Person shall be the amount of such Indemnified Person's actual Loss, net of any insurance or other recovery.

64.5 Limitation on Damages. Except as otherwise provided in this Section 64, the liability of an Interconnection Party under this Subpart E shall be limited to direct

- Ⓜ actual damages, and all other damages at law are waived. Under no circumstances shall any Interconnection Party or its Affiliates, directors, officers, employees and agents, or any of them, be liable to another Interconnection Party, whether in tort, contract or other basis in law or equity for any special, indirect, punitive, exemplary or consequential damages, including lost profits. The limitations on damages specified in this Section 64.5 are without regard to the cause or causes related thereto, including the negligence of any Interconnection Party, whether such negligence be sole, joint or concurrent, or active or passive. This limitation on damages shall not affect any Interconnection Party's rights to obtain equitable relief as otherwise provided in this Subpart. The provisions of this Section 64.5 shall survive the termination or expiration of the Interconnection Service Agreement.

64.6 Limitation of Liability in Event of Breach. An Interconnection Party ("Breaching Party") shall have no liability hereunder to the other Interconnection Parties, and the other Interconnection Parties hereby release the Breaching Party, for all claims or damages that either of them incurs that are associated with any interruption in the availability of the Customer Facility, Interconnection Facilities, Transmission System or Interconnection Service or damages to an Interconnection Party's facilities, except to the extent such interruption or damage is caused by the Breaching Party's gross negligence or willful misconduct in the performance of its obligations under this Subpart of the Tariff or the Interconnection Service Agreement.

64.7 Limited Liability in Emergency Conditions. Except as otherwise provided in the Tariff or the Operating Agreement, no Interconnection Party shall be liable to any other Interconnection Party for any action that it takes in responding to an Emergency Condition, so long as such action is made in good faith, is consistent with Good Utility Practice and is not contrary to the directives of the Transmission Provider or of the Interconnected Transmission Owner with respect to such Emergency Condition. Notwithstanding the above, Interconnection Customer shall be liable in the event that it fails to comply with any instructions of Transmission Provider or the Interconnected Transmission Owner related to an Emergency Condition.

65 Breach, Cure And Default

65.1 Breach. A Breach of this Subpart and the Interconnection Service Agreement shall include:

- (a) The failure to pay any amount when due;
- (b) The failure to comply with any material term or condition of this Subpart, including but not limited to any material breach of a representation, warranty or covenant (other than in subsections (a) and (c)-(e) of this Section) made in this Subpart;
- (c) Assignment of the Interconnection Service Agreement in a manner inconsistent with its terms;
- (d) Failure of an Interconnection Party to provide access rights, or an Interconnection Party's attempt to revoke or terminate access rights, that are provided under this Subpart; or
- (e) Failure of an Interconnection Party to provide information or data required to be provided under this Subpart E to another Interconnection Party for such other Interconnection Party to satisfy its obligations under this Subpart.

65.2 Continued Operation. In the event of a Breach or Default by either Interconnected Entity, and subject to termination of the Interconnection Service Agreement under Section 66 of this Subpart, the Interconnected Entities shall continue to operate and maintain, as applicable, such DC power systems, protection and Metering Equipment, telemetering equipment, SCADA equipment,

transformers, Secondary Systems, communications equipment, building facilities, software, documentation, structural components, and other facilities and appurtenances that are reasonably necessary for Transmission Provider and the Interconnected Transmission Owner to operate and maintain the Transmission System and the Transmission Owner Interconnection Facilities and for Interconnection Customer to operate and maintain the Customer Facility and the Customer Interconnection Facilities, in a safe and reliable manner.

65.3 Notice of Breach. An Interconnection Party not in Breach shall give written notice of an event of Breach to the Breaching Party, to Transmission Provider and to other persons that the Breaching Party identifies in writing to the other Interconnection Party in advance. Such notice shall set forth, in reasonable detail, the nature of the Breach, and where known and applicable, the steps necessary to cure such Breach. In the event of a Breach by Interconnection Customer, Transmission Provider and the Interconnected Transmission Owner agree to provide notice of such Breach, at the same time and in the same manner as its notice to Interconnection Customer, to any Project Finance Entity provided that the Interconnection Customer has provided the notifying Interconnection Party with notice of an assignment to such Project Finance Entity(ies) and identifies such Project Finance Entity(ies) as contacts for notice purposes pursuant to Section 71 of Subpart E.

65.4 Cure and Default. An Interconnection Party that commits a Breach and does not take steps to cure the Breach pursuant to this Section 65.4 is in Default of this Subpart and of the Interconnection Service Agreement.

65.4.1 Cure of Breach. Except for the event of Breach set forth in Section 65.1(a) above, the Breaching Interconnection Party (a) may cure the Breach within thirty days from the receipt of such notice; or (b) if the Breach cannot be cured within thirty (30) days, may commence in good faith all steps that are reasonable and appropriate to cure the Breach within such thirty day time period and thereafter diligently pursue such action to completion. In an event of Breach set forth in Section 65.1(a), the Breaching Interconnection Party may cure the Breach within five (5) days from the receipt of notice of the Breach.

65.5 Right to Compel Performance. Notwithstanding the foregoing, upon the occurrence of an event of Default, a non-Defaulting Interconnection Party shall be entitled to (a) commence an action to require the Defaulting Interconnection Party to remedy such Default and specifically perform its duties and obligations hereunder in accordance with the terms and conditions hereof, (b) withhold payments, (c) suspend performance hereunder, and (d) exercise such other rights and remedies as it may have in equity or at law; provided, however, that the Transmission Provider shall not terminate the Interconnection Service Agreement due to the failure of Interconnection Customer to make a payment hereunder unless such failure could reasonably be expected to have a material adverse effect on the Interconnected Transmission Owner.

65.6 Remedies Cumulative. Subject to Section 70.1, no remedy conferred by any provision of this Subpart is intended to be exclusive of any other remedy and each and every remedy shall be cumulative and shall be in addition to every other remedy given hereunder or now or hereafter existing at law or in equity or by statute or otherwise. The election of any one or more remedies shall not constitute a waiver of the right to pursue other available remedies.

66 Termination

66.1 Termination. The Interconnection Service Agreement and Interconnection Service under this Subpart may be terminated by the following means:

66.1.1 By Mutual Consent. Interconnection Service may be terminated as of the date on which the Interconnection Parties mutually agree to terminate the Interconnection Service Agreement.

66.1.2 By Interconnection Customer. Interconnection Customer may unilaterally terminate the Interconnection Service Agreement pursuant to Applicable Laws and Regulations upon providing Transmission Provider and the Interconnected Transmission Owner sixty (60) days prior written notice thereof, provided that Interconnection Customer is not then in Default under this Subpart or the Interconnection Service Agreement.

66.1.3 Upon Default of Interconnection Customer. Transmission Provider may terminate the Interconnection Service Agreement upon the Default of Interconnection Customer of its obligations under this Subpart or the Interconnection Service Agreement; provided, however, that Transmission Provider shall not terminate the Interconnection Service Agreement due to the failure of Interconnection Customer to make a payment hereunder unless such failure could reasonably be expected to have a material adverse effect on the Interconnected Transmission Owner.

66.2 Disposition of Facilities Upon Termination.

66.2.1 Disconnection. Upon termination of the Interconnection Service Agreement in accordance with this Section 66, Transmission Provider and/or the Interconnected Transmission Owner shall, in coordination with Interconnection Customer, physically disconnect the Customer Facility from the Transmission System, except to the extent otherwise allowed by this Subpart.

66.2.2 Network Facilities. At the time of termination, the Transmission Provider and the Interconnected Entities shall keep in place any portion of the Interconnection Facilities and/or of any Merchant Network Upgrades that the Transmission Provider deems necessary for the safety, integrity and/or reliability of the Transmission System. Otherwise, Transmission Provider may, in its discretion, within 30 days following termination of Interconnection Service, require the removal of all or any part of the Interconnection Facilities or of any Merchant Network Upgrades.

66.2.2.1 In the event that (i) the Interconnection Service Agreement and Interconnection Service under this Subpart are terminated and (ii) Transmission Provider determines that some or all of the Interconnection Facilities or of any Merchant Network Upgrades that are owned by the Interconnection Customer are necessary for the safety, integrity and/or reliability of the Transmission System, Interconnection Customer, subject to Applicable Laws and Regulations, shall transfer to the Interconnected Transmission Owner title to the Interconnection Facilities or Merchant Network Upgrades that Transmission Provider has determined to be necessary for the safety, integrity and/or reliability of the Transmission System.

66.2.2.2 In the event that removal of some or all of the Interconnection Facilities or any Merchant Network Upgrades is necessary to maintain compliance with Applicable Standards, Interconnection Customer shall be responsible for the costs of any such removal. Interconnection Customer shall have the right to take or retain title to equipment and/or facilities that are removed pursuant to this section; alternatively, in the event that the Interconnection Customer does not wish to retain title to removed equipment and/or facilities that it owns, the Interconnected Transmission Owner may elect to pay the Interconnection Customer a mutually agreed amount to acquire and own such equipment and/or facilities.

66.2.3 Request for Disposition Determination. Interconnection Customer may request a determination from the Transmission Provider whether any Interconnection Facilities or any Merchant Network Upgrades will be removed in the event of any termination of Interconnection Service to the Customer Facility within the following year. Transmission Provider shall respond to that request no later than sixty (60) days after receipt.

66.3 FERC Approval. Notwithstanding any other provision of this Subpart, no termination hereunder shall become effective until the Interconnected Entities and/or Transmission Provider have complied with all Applicable Laws and Regulations applicable to such termination, including the filing with the FERC of a notice of termination of the Interconnection Service Agreement, and acceptance of such notice for filing by the FERC.

66.4 Survival of Rights. Termination of the Interconnection Service Agreement shall not relieve any Interconnection Party of any of its liabilities and obligations arising under this Subpart or the Interconnection Service Agreement prior to the date on which termination becomes effective, and each Interconnection Party may take whatever judicial or administrative actions it deems desirable or necessary to enforce its rights hereunder. Applicable provisions of this Subpart will continue in effect after termination to the extent necessary to provide for final billings, billing adjustments, and the determination and enforcement of liability and indemnification obligations arising from events or acts that occurred while the Interconnection Service Agreement was in effect.

67 Confidentiality

67.1 Scope. Confidential Information shall not include information that the receiving Interconnection Party can demonstrate (i) is generally available to the public other than as a result of a disclosure by the receiving Interconnection Party; (ii) was lawfully available to the receiving Interconnection Party on a non-confidential basis before receiving it from the disclosing Interconnection Party; (iii) was supplied to the receiving Interconnection Party without restriction by a third party, who, to the knowledge of the receiving Interconnection Party, after due inquiry, was under no obligation to the other Interconnection Party to keep such information confidential; (iv) was independently developed by the receiving Interconnection Party without reference to Confidential Information of the disclosing Interconnection Party; (v) is, or becomes, publicly known, through no wrongful act or omission of the receiving Interconnection Party or breach of this Subpart; or (vi) is required, in accordance with Section 67.6 of this Subpart, to be disclosed to any Governmental Authority as long as such information is made available to the public, is otherwise required to be disclosed by Applicable Laws and Regulations or subpoena, or is necessary in any legal proceeding establishing rights and obligations under this Subpart. Information designated as Confidential Information shall no longer be deemed confidential if the Interconnection Party that designated the information as confidential notifies the other Interconnection Parties that it no longer is confidential.

67.2 Duration of Obligations. During the term of the Interconnection Service Agreement, and for a period of three (3) years after the expiration or termination of the Interconnection Service Agreement, except as otherwise provided in this Section 67, each Interconnection Party shall hold in confidence, and shall not disclose to any person, Confidential Information provided to it by any other Interconnection Party.

67.3 Use of Confidential Information. An Interconnection Party shall not use Confidential Information of any other Interconnection Party for any purpose other than to fulfill its obligations under this Subpart and the Interconnection Service Agreement or to comply with Applicable Laws and Regulations. No Interconnection Party shall release or disclose Confidential Information to any other person, except to its employees, representatives, or agents on a need-to-know basis (and only after advising such persons of the confidentiality provisions of this Section 67 and obtaining their agreement to comply with such provisions), unless compelled to disclose by judicial or administrative process or Applicable Laws and Regulations. Notwithstanding the foregoing, an Interconnection Party providing Confidential Information of any other Interconnection Party to any person pursuant to this Section 67.3 shall remain primarily responsible for any release of Confidential Information in contravention of this Section 67.

67.4 Standard of Care. Each Interconnection Party shall use at least the same standard of care to protect Confidential Information of each other Interconnection Party as the Interconnection Party uses to protect its own Confidential Information from unauthorized disclosure, publication or dissemination.

67.5 Rights. Each Interconnection Party retains all rights, title, and interest in the Confidential Information that it discloses to any other Interconnection Party. An Interconnection Party's disclosure to another Interconnection Party of Confidential Information shall not be deemed a waiver by any Interconnection Party or any other person or entity of the right to protect the Confidential Information from public disclosure.

67.6 Order of Disclosure. If a Governmental Authority with the right, power, and apparent authority to do so requests or requires an Interconnection Party, by subpoena, oral deposition, interrogatories, requests for production of documents, data request, administrative order, or otherwise, to disclose Confidential Information, that Interconnection Party shall provide the Interconnection Party that provided the information with prompt prior written notice to the extent possible of such request(s) or requirement(s) so that the providing Interconnection Party may seek an appropriate protective order or agreement, or waive compliance with the terms of this Subpart. Notwithstanding the absence of a protective order or agreement, or waiver, the Interconnection Party that is subjected to the request or order may disclose such Confidential Information which, in the opinion of its counsel, the Interconnection Party is legally compelled to disclose. Each Interconnection Party shall use Reasonable Efforts to obtain reliable assurance that confidential treatment will be accorded any Confidential Information so furnished.

67.7 Remedies. The Interconnection Parties expressly agree that monetary damages would be inadequate to compensate an Interconnection Party for another Interconnection Party's Breach of its obligations under this Section 67. Each Interconnection Party accordingly expressly agrees that the other Interconnection Parties shall be entitled to equitable relief, by way of injunction or otherwise, if the first Interconnection Party breaches or threatens to breach its obligations under this Section 67, which equitable relief shall be granted without bond or proof of injury, and the receiving Interconnection Party shall not plead in defense that there would be an adequate remedy at law. Such remedy shall not be deemed to be an exclusive remedy for the breach of this Section 67, but shall be in addition to all other remedies available at law or in equity. The Interconnection Parties further acknowledge and agree that the covenants contained herein are necessary for the protection of legitimate business interests and are reasonable in scope. No Interconnection Party, however, shall be liable for indirect, incidental or consequential or punitive damages of any nature or kind resulting from or arising in connection with this Section 67.

67.8 Return or Destruction of Confidential Information. If an Interconnection Party provides any Confidential Information to another Interconnection Party in the course of an audit or inspection, the providing Interconnection Party may request the other party to return or destroy such Confidential Information after the termination of the audit period and the resolution of all matters relating to that audit. Each Interconnection Party shall make Reasonable Efforts to comply with any such requests for return or destruction within ten days of receiving the request and shall certify in writing to the other Interconnection Party that it has complied with such request.

67.9 Upon Termination of Interconnection Service. Upon termination of the Interconnection Service Agreement for any reason, each Interconnection Party shall, at the party's option, within ten (10) days after receipt of a written request from the other party, use Reasonable Efforts to destroy, erase, or delete (with such destruction, erasure and deletion certified in writing to the other party) or to return to the other party, without retaining copies thereof, any and all written or electronic Confidential Information received from the other party.

68 Subcontractors

68.1 Use of Subcontractors. Nothing in this Subpart shall prevent the Interconnection Parties from utilizing the services of subcontractors as they deem appropriate to perform their respective obligations hereunder, provided, however, that each Interconnection Party shall require its subcontractors to comply with all applicable terms and conditions of this Subpart in providing such services.

68.2 Responsibility of Principal. The creation of any subcontract relationship shall not relieve the hiring Interconnection Party of any of its obligations under this Subpart. Each Interconnection Party shall be fully responsible to the other Interconnection Parties for the acts and/or omissions of any subcontractor it hires as if no subcontract had been made.

68.3 Indemnification by Subcontractors. To the fullest extent permitted by law, an Interconnection Party that uses a subcontractor to carry out any of the Interconnection Party's obligations under this Subpart shall require each of its subcontractors to indemnify, hold harmless and defend each other Interconnection Party, its representatives and assigns from and against any and all claims and/or liability for damage to property, injury to or death of any person, including the employees of any Interconnection Party or of any Affiliate of any Interconnection Party, or any other liability incurred by the other Interconnection Party or any of its Affiliates, including all expenses, legal or otherwise, to the extent caused by any act or omission, negligent or otherwise, by such subcontractor and/or its officers, directors, employees, agents and assigns, that arises out of or is connected with the operation of the facilities of either Interconnected Entity described in this Subpart; provided, however, that no Interconnection Party or Affiliate thereof shall be entitled to indemnity under this Section 68.3 in respect of any injury, loss, or damage to the extent that such loss, injury, or damage results from the negligence or willful misconduct of the Interconnection Party or Affiliate seeking indemnity.

68.4 Subcontractors Not Beneficiaries. No subcontractor is intended to be, or shall be deemed to be, a third-party beneficiary of an Interconnection Service Agreement.

69 Information Access And Audit Rights

69.1 Information Access. Consistent with Applicable Laws and Regulations, each Interconnection Party shall make available such information and/or documents reasonably requested by another Interconnection Party that are necessary to (i) verify the costs incurred by the other Interconnection Party for which the requesting Interconnection Party is responsible under this Subpart and (ii) carry out obligations and responsibilities under this Subpart, provided that the Interconnection Parties shall not use such information for purposes other than those set forth in this Section 69.1 and to enforce their rights under this Subpart.

69.2 Reporting of Non-Force Majeure Events. Each Interconnection Party shall notify the other Interconnection Parties when it becomes aware of its inability to comply with the provisions of this Subpart for a reason other than Force Majeure. The parties agree to cooperate with each other and provide necessary information regarding such inability to comply, including, but not limited to, the date, duration, reason for the inability to comply, and corrective actions taken or planned to be taken with respect to such inability to comply. Notwithstanding the foregoing, notification, cooperation or information provided under this Section shall not entitle the receiving Interconnection Party to allege a cause of action for anticipatory breach of the Interconnection Service Agreement.

69.3 Audit Rights. Subject to the requirements of confidentiality under Section 67 of this Subpart, each Interconnection Party shall have the right, during normal business hours, and upon prior reasonable notice to the pertinent other Interconnection Party, to audit at its own expense the other Interconnection Party's accounts and records pertaining to such Interconnection Party's performance and/or satisfaction of obligations arising under this Subpart. Any audit authorized by this Section shall be performed at the offices where such accounts and records are maintained and shall be limited to those portions of such accounts and records that relate to obligations under this Subpart. Any request for audit shall be presented to the Interconnection Party to be audited not later than twenty-four months after the event as to which the audit is sought. Each Interconnection Party shall preserve all records held by it for the duration of the audit period.

70 Disputes

70.1 Submission. Any claim or dispute that any Interconnection Party may have against another arising out of this Subpart E or the Interconnection Service Agreement may be submitted for resolution in accordance with the dispute resolution provisions of the Tariff.

70.2 Rights Under The Federal Power Act. Nothing in this Section shall restrict the rights of any Interconnection Party to file a complaint with FERC under relevant provisions of the Federal Power Act.

70.3 Equitable Remedies. Nothing in this Section shall prevent any Interconnection Party from pursuing or seeking any equitable remedy available to it under Applicable Laws and Regulations.

71 Notices

71.1 General. Any notice, demand or request required or permitted to be given by any Interconnection Party to another and any instrument required, or permitted to be tendered or delivered by any Interconnection Party in writing to another may be so given, tendered or delivered, by recognized national courier, or by depositing the same with the United States Postal Service with postage prepaid, for delivery by certified or registered mail, addressed to the Interconnection Party, or personally delivered to the Interconnection Party, at the address specified in the Interconnection Service Agreement. Such notices, if agreed to by the Interconnection Parties, may be made via electronic means, with e-mail confirmation of delivery.

71.2 Emergency Notices. Moreover, notwithstanding the foregoing, any notice hereunder concerning an Emergency Condition or other occurrence requiring prompt attention, or as necessary during day-to-day operations, may be made by telephone or in person, provided that such notice is confirmed in writing promptly thereafter. Notice in an Emergency Condition, or as necessary during day-to-day operations, shall be provided (i) if by the Interconnected Transmission Owner, to the shift supervisor at, as applicable, a Generation Interconnection Customer's Customer Facility or a Transmission Interconnection Customer's control center; and (ii) if by the Interconnection Customer, to the shift supervisor at the Interconnected Transmission Owner's transmission control center.

71.3 Operational Contacts. Each Interconnection Party shall designate, and provide to each other Interconnection Party contact information concerning, a representative to be responsible for addressing and resolving operational issues as they arise during the term of the Interconnection Service Agreement.

72 Miscellaneous

72.1 Regulatory Filing. Transmission Provider shall file the Interconnection Service Agreement on behalf of itself and the Interconnected Transmission Owner and any amendments to such agreement(s) with FERC as a service schedule under Part IV, Subpart E of the Tariff within thirty days after execution. An Interconnection Customer shall have the right, with respect to any Interconnection Service Agreement tendered to it, to request (a) dispute resolution under Section 12 of the Tariff or, if concerning the Regional Transmission Expansion Plan, consistent with Schedule 5 of the Operating Agreement, or (b) that Transmission Provider file the agreement unexecuted with the Commission. With the filing of any unexecuted Interconnection Service Agreement, Transmission Provider may, in its discretion, propose to FERC a resolution of any or all of the issues in dispute between or among the Interconnection Parties.

72.2 **Waiver.** Any waiver at any time by an Interconnection Party of its rights with respect to a Breach or Default under this Subpart, or with respect to any other matters arising in connection with this Subpart, shall not be deemed a waiver or continuing waiver with respect to any subsequent Breach or Default or other matter.

72.3 **Amendments and Rights Under the Federal Power Act.** The Interconnection Service Agreement may be amended or supplemented only by a written instrument duly executed by all Interconnection Parties. An amendment, to the Interconnection Service Agreement shall become effective and a part of the Interconnection Service Agreement upon satisfaction of all Applicable Laws and Regulations. Notwithstanding the foregoing, nothing contained in the Interconnection Service Agreement shall be construed as affecting in any way any of the rights of any Interconnection Party with respect to changes in applicable rates or charges under Section 205 of the Federal Power Act and/or FERC's rules and regulations thereunder, or any of the rights of any Interconnection Party under Section 206 of the Federal Power Act and/or FERC's rules and regulations thereunder. The terms and conditions of this Subpart, the Interconnection Service Agreement and every appendix referred to therein shall be amended, as mutually agreed by the Interconnection Parties, to comply with changes or alterations made necessary by a valid applicable order of any Governmental Authority having jurisdiction hereof.

72.4 **Binding. Effect.** The Interconnection Service Agreement and this Subpart E and the rights and obligations thereunder shall be binding upon, and shall inure to the benefit of, the successors and assigns of the Interconnection Parties.

72.5 **Regulatory Requirements.** Each Interconnection Party's performance of any obligation under this Subpart E for which such party requires approval or authorization of any Governmental Authority shall be subject to its receipt of such required approval or authorization in the form and substance satisfactory to the receiving Interconnection Party, or the Interconnection Party making any required filings with, or providing, notice to, such Governmental Authorities, and the expiration of any time period associated therewith. Each Interconnection Party shall in good faith seek, and shall use Reasonable Efforts to obtain, such required authorizations or approvals as soon as reasonably practicable.

73 **Representations And Warranties**

73.1 **General.** Each Interconnected Entity hereby represents, warrants and covenants as follows with these representations, warranties, and covenants effective as to the Interconnected Entity during the time the Interconnection Service Agreement is effective:

73.1.1 **Good Standing.** Such Interconnected Entity is duly organized or formed, as applicable, validly existing and in good standing under the laws of its State of organization or formation, and is in good standing under the laws of the respective State(s) in which it is incorporated and operates as stated in the Interconnection Service Agreement.

73.1.2 Authority. Such Interconnected Entity has the right, power and authority to enter into the Interconnection Service Agreement, to become a party hereto and to perform its obligations hereunder. The Interconnection Service Agreement is a legal, valid and binding obligation of such Interconnected Entity, enforceable against such Interconnected Entity in accordance with its terms, except as the enforceability thereof may be limited by applicable bankruptcy, insolvency, reorganization or other similar laws affecting creditors' rights generally and by general equitable principles (regardless of whether enforceability is sought in a proceeding in equity or at law).

73.1.3 No Conflict. The execution, delivery and performance of the Interconnection Service Agreement does not violate or conflict with the organizational or formation documents, or bylaws or operating agreement, of the Interconnected Entity, or with any judgment, license, permit, order, material agreement or instrument applicable to or binding upon the Interconnected Entity or any of its assets.

73.1.4 Consent and Approval. Such Interconnected Entity has sought or obtained, or, in accordance with the Interconnection Service Agreement will seek or obtain, each consent, approval, authorization, order, or acceptance by any Governmental Authority in connection with the execution, delivery and performance of the Interconnection Service Agreement and it will provide to any Governmental Authority notice of any actions under this Subpart that are required by Applicable Laws and Regulations.

74-79

[Reserved]

Schedule A

Customer Facility Location / Site Plan

Not Applicable. Customer Facility is already interconnected.

Schedule B
One Line Diagram

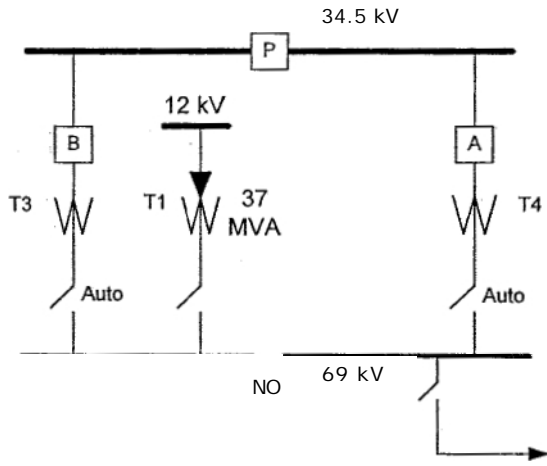

1
 To other
 Mannington Mills
 Load

Salem

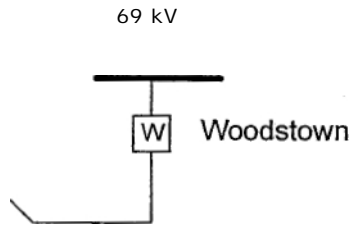

C kt. 0745

Point of Interconnection
 (POI)

69 kV

4.16 kV

Meter (Owned by Atlantic City Electric)

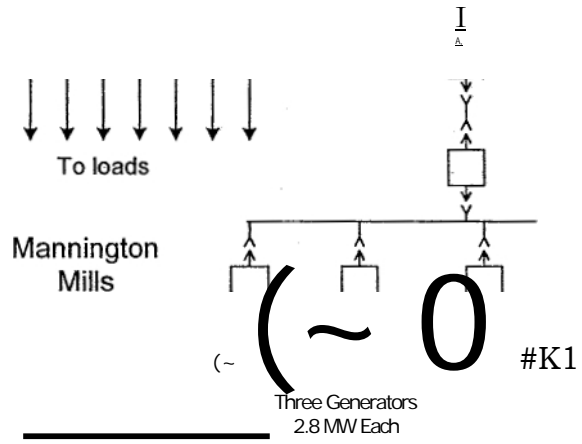

05/27/02



Schedule C

List and Ownership of Facilities

Interconnected Transmission Owner:

None.

Interconnection Customer:

None.

Schedule D
Ownership and Location of Metering Equipment

Metering Equipment to be provided by Interconnected Transmission Owner: None.

Metering and Telemetry Equipment to be installed by the Interconnection Customer:

Interconnection Customer shall meet the Conectiv Power Delivery metering and telemetry requirements of Schedule D of this ISA before exporting energy for sale as an Energy Resource.

Interconnection Customer is responsible for providing the following data to Interconnected Transmission Owner (Conectiv) and Transmission Provider (PJM)*:

(*Upon approval by PJM data described above may be provided to PJM by Atlantic City Electric via existing data links)

Real Time (Telemetry) transmitted to Conectiv via RTU

Generation injection into system net of on-site load measured at Point of Interconnection (POI) as shown on Schedule B:

- Megawatts
- Megavars
- Megawatt hours
- Megavar hours

Generation units (Aggregate of all 3 generating units):

- Megawatts
- Megavars

Generator Circuit Breaker Status:

- Open/Closed breaker positions are required for each of the 3 generator breakers shown on Schedule B.

Interval Data for Units 1, 2 & 3 combined (hone line acid recorder device required to allow dial up by Conectiv)

Generation injection into system net of on-site load measured at Point of Interconnection (POI) as shown on Schedule B:

- Megawatt hours
- Megavar hours

Generation units (Aggregate of all 3 generating units):

- Megawatt hours
- Megavar hours

Schedule E

Applicable Technical Requirements and Standards

Conectiv Power Delivery *"Technical Considerations Covering Parallel Operations of Customer Owned Generation In Accordance with PJM Tariff Provisions And Interconnected with the Conectiv Power Delivery System"*, dated May 9, 2003.

Conectiv Power Delivery *"Operations and Modifications Requirements of Atlantic City Electric Company Atlantic City Electric Company d.b.a Conectiv Power Delivery (CPD) being a part of CPD Applicable Technical Requirements and Standards "*, dated May 9, 2003.

Schedule F

Schedule of Charges

None.

SCHEDULE G

SCHEDULE OF NON-STANDARD TERMS & CONDITIONS

Section 67, Confidentiality, included in Appendix 2, the Standard Terms and Conditions, of this ISA is revised to include the following:

Notwithstanding anything in section 67 to the contrary, if the FERC or its staff, during the course of an investigation or otherwise, requests information from one of the Parties that is otherwise required to be maintained in confidence pursuant to

this Interconnection Service Agreement, the Party shall provide the requested information to the FERC or its staff, within the time provided for in the request for information. In providing the information to FERC or its staff, the Party may, consistent with 18 C.F.R. § 388.112, request that the information be treated as confidential and non-public by the FERC and its staff and that the information be withheld from public disclosure. The Party shall notify the affected party to the Interconnection Service Agreement when it is notified by FERC or its staff that a request for disclosure of, or decision to disclose, confidential information has been received, at which time any of the Parties may respond before such information is made public, pursuant to 18 C.F.R. § 388.112.

~ j - 'a, 7-Alo ~
i ~ j ~ Pal ~m MSMA&'o

SCHEDULE G

SCHEDULE OF NON-STANDARD TERMS & CONDITIONS

Section 67, Confidentiality, included in Appendix 2, the Standard Terms and Conditions, of this ISA is revised to include the following:

Notwithstanding anything in section 67 to the contrary, if the FERC or its staff, during the course of an investigation or otherwise, requests information from one of the Parties that is otherwise [required. to](#) be maintained in confidence pursuant to this Interconnection Service Agreement, the Party shall provide the requested information to the FERC or its staff, within the time provided for in the request for information. In providing the information to FERC or its staff, the Party may, consistent with 18 C.F.R. § 388.112, request that the information be treated as confidential and non-public by the FERC and its staff and that the information be withheld from public disclosure. The Party shall notify the affected party to the Interconnection Service Agreement when it is notified by FERC or its staff that a request for disclosure of, or decision to disclose, confidential information has been received, at which time any of the Parties may respond before such information is made public, pursuant to 18 C.F.R. § 388.112.

SCHEDULE G

SCHEDULE OF NON-STANDARD TERMS & CONDITIONS

Section 67, Confidentiality, included in Appendix 2, the Standard Terms and Conditions, of this ISA is revised to include the following:

Notwithstanding anything in section 67 to the contrary, if the FERC or its staff, during the course of an investigation or otherwise, requests information from one of the Parties that is otherwise required to be maintained in confidence pursuant to this Interconnection Service Agreement, the Party shall provide the requested information to the FERC or its staff, within the time provided for in the request for information. In providing the information to FERC or its staff, the Party may, consistent with 18 C.F.R. § 388.112, request that the information be treated as confidential and non-public by the FERC and its staff and that the information be withheld from public disclosure. The Party shall notify the affected party to the Interconnection Service Agreement when it is notified by FERC or its staff that a request for disclosure of, or decision to disclose, confidential information has been received, at which time any of the Parties may respond before such information is made public, pursuant to 18 C.F.R. § 388.112.

Notice of Filing

Comment Date:

**UNITED STATES OF AMERICA
BEFORE THE
FEDERAL ENERGY REGULATORY COMMISSION**

PJM Interconnection, L.L.C.) Docket No. ER04 _____ **NOTICE OF FILING**

Take notice that on January 25, 2004, PJM Interconnection, L.L.C. ("PJM"), submitted for filing an executed interconnection service agreement ("ISA") among PJM, Mannington Mills, Inc., and Atlantic City Electric Company d/b/a Conectiv Power Delivery.

PJM requests a waiver of the Commission's 60-day notice requirement to permit a January 27, 2004 effective date for the ISA.

Copies of this filing were served upon the parties to the agreements and the state regulatory commissions within the PJM region.

Any person desiring to intervene or to protest this filing should file with the Federal Energy Regulatory Commission, 888 First Street, N.E., Washington, D.C. 20426, in accordance with Rules 211 and 214 of the Commission's Rules of Practice and Procedure (18 CFR 385.211 and 385.214). Protests will be considered by the Commission in determining the appropriate action to be taken, but will not serve to make Protestants parties to the proceeding. Any person wishing to become a party must file a motion to intervene. All such motions or protests should be filed on or before the comment date, and, to the extent applicable, must be served on the applicant and on any other person designated on the official service list. This filing is available for review at the Commission or may be viewed on the Commission's web site at <http://www.ferc.gov>, using the eLibrary (FERRIS) link. Enter the docket number excluding the last three digits in the docket number field to access the document. For assistance, please contact FERC Online Support at FERCOnlineSupport@ferc.gov or toll-free at (866)208-3676, or for TTY, contact (202)502-8659. Protests and interventions may be filed electronically via the Internet in lieu of paper; see 18 CFR 385.2001(a)(1)(iii) and the instructions on the Commission's web site under the "e-Filing" link. The Commission strongly encourages electronic filings.