

FEDERAL ENERGY REGULATORY COMMISSION
WASHINGTON, DC 20426

OFFICE OF ENERGY MARKET REGULATION

PJM Interconnection, L.L.C.
Docket No. ER23-2574-000

Issued: October 4, 2023

On August 7, 2023, PJM Interconnection, L.L.C. (PJM) submitted a notice of cancellation of the Wholesale Market Participation Agreement among PJM, Penn State Solar LLC, and West Penn Power Company, designated as Service Agreement No. 6328.¹ Pursuant to authority delegated to the Director, Division of Electric Power Regulation – East, under 18 C.F.R. § 375.307, the submittal is accepted for filing, effective October 6, 2023, as requested.

The filing was publicly noticed. No protests or adverse comments were filed. Pursuant to Rule 214 of the Commission’s regulations (18 C.F.R. § 385.214), notices of intervention, timely-filed motions to intervene, and any unopposed motions to intervene out-of-time filed before the issuance date of this order are granted.

This action does not constitute approval of any service, rate, charge, classification, or any rule, regulation, contract, or practice affecting such rate or service provided for in the filed document(s); nor shall such action be deemed as recognition of any claimed contractual right or obligation affecting or relating to such service or rate; and such action is without prejudice to any findings or orders which have been or may hereafter be made by the Commission in any proceeding now pending or hereafter instituted by or against the applicant(s).

This order constitutes final agency action. Requests for rehearing by the Commission may be filed within 30 days of the date of issuance of this order, pursuant to 18 C.F.R. § 385.713.

Issued by: Kurt M. Longo, Director, Division of Electric Power Regulation – East

¹ PJM Interconnection, L.L.C., PJM Service Agreements Tariff, [PJM SA No. 6328, PJM SA # 6328 among PJM, Penn State Solar & West Penn Power \(1.0.0\)](#).

Document Content(s)

ER23-2574-000 DLO.docx.....1



PJM Interconnection, L.L.C.
2750 Monroe Blvd
Audubon, PA 19403-2497

Salvia Yi
Contract Counsel, Office of General Counsel
Salvia.Yi@pjm.com

August 7, 2023

The Honorable Kimberly D. Bose, Secretary
Federal Energy Regulatory Commission
888 First Street, N.E., Room 1A
Washington, D.C. 20426-0001

Re: PJM Interconnection, L.L.C., Docket No. ER23-2574-000

Notice of Cancellation of Service Agreement No. 6328, Queue No. AG2-399

Dear Secretary Bose:

PJM Interconnection, L.L.C. (“PJM”) hereby submits to the Federal Energy Regulatory Commission (“Commission”) this notice of cancellation of the Wholesale Market Participation Agreement (“WMPA”) among PJM, Penn State Solar LLC (“Penn State Solar”), and West Penn Power Company (“WPP”), designated as Service Agreement No. 6328 and accepted by the Commission in Docket No. ER22-919-000 (“Penn State Solar WMPA”).¹ On June 13, 2023, PJM notified Penn State Solar of its breach of the Penn State Solar WMPA for failing to meet a material term or condition under the Penn State Solar WMPA. Penn State Solar failed to cure the breach, thus resulting in default of the Penn State Solar WMPA. Therefore, PJM hereby notifies the Commission that Service Agreement No. 6328 is cancelled effective October 6, 2023.

¹ *PJM Interconnection, L.L.C.*, Letter Order, Docket No. ER22-919-000 (Mar. 24, 2022).

I. WAIVER AND EFFECTIVE DATE

PJM requests an effective date of October 6, 2023 for the cancellation of Service Agreement No. 6328, in accordance with the sixty (60) day notice requirement in section 35.15 of the Commission's regulations.² The Parties have no remaining obligations under Service Agreement No. 6328.

II. CORRESPONDENCE AND COMMUNICATION

All notices, communications, or correspondence to PJM regarding this matter should be directed to the following:

Craig Glazer
Vice President–Federal Government Policy
PJM Interconnection, L.L.C.
1200 G Street, N.W, Suite 600
Washington, D.C. 20005
(202) 423-4743
Craig.Glazer@pjm.com

Salvia Yi
Contract Counsel
PJM Interconnection, L.L.C.
2750 Monroe Blvd
Audubon, PA 19403-2497
Salvia.Yi@pjm.com

Christopher Holt
Associate General Counsel
PJM Interconnection, L.L.C.
2750 Monroe Blvd
Audubon, PA 19403-2497
(610) 666-2368
Christopher.Holt@pjm.com

² 18 C.F.R. § 35.15 (2020).

III. SERVICE

PJM has served a copy of this filing on Penn State Solar, WPP, and the state utility regulatory commissions within the PJM Region.

Respectfully submitted,

/s/ Salvia Yi

Craig Glazer
Vice President–Federal Government Policy
PJM Interconnection, L.L.C.
1200 G Street, N.W, Suite 600
Washington, D.C. 20005
(202) 423-4743
Craig.Glazer@pjm.com

Salvia Yi
Contract Counsel
PJM Interconnection, L.L.C.
2750 Monroe Blvd
Audubon, PA 19403-2497
Salvia.Yi@pjm.com

Christopher Holt
Associate General Counsel
PJM Interconnection, L.L.C.
2750 Monroe Blvd
Audubon, PA 19403-2497
(610) 666-2368
Christopher.Holt@pjm.com

cc (via email):

Penn State Solar LLC
Jared Perram - jared.perram@saturnpower.com

West Penn Power Company
Mike Thorn - mthorn@firstenergycorp.com
Amanda Parker - aparker@firstenergycorp.com
Tricia Hartzell - thartzell@firstenergycorp.com

PJM
Edward Jablonski – Edward.Jablonski@pjm.com

All state utility regulatory commissions within the PJM Region

FEDERAL ENERGY REGULATORY COMMISSION
WASHINGTON, D.C. 20426

OFFICE OF ENERGY MARKET REGULATION

In Reply Refer To:
PJM Interconnection, L.L.C.
Docket No. ER22-919-000

Issued: March 24, 2022

PJM Interconnection, L.L.C.
2750 Monroe Blvd
Audubon, PA 19403
Attention: Christopher Holt

Reference: Wholesale Market Participation Agreement No. 6328

On January 28, 2022, PJM Interconnection, L.L.C. (PJM) filed an executed Wholesale Market Participation Agreement (WMPA) entered into among PJM, Penn State Solar LLC (Penn State Solar) and West Penn Power Company (West Penn Power), designated as Service Agreement No. 6328.¹ PJM states that it is submitting the WMPA for filing because Penn State Solar requested interconnection of its generating facility to West Penn Power's non-jurisdictional facilities to engage in wholesale transactions in the PJM markets.

Pursuant to the authority delegated to the Director, Division of Electric Power Regulation - East, under 18 C.F.R. § 375.307 (2021), your submittal is accepted for filing, effective January 19, 2022, as requested.²

The filing was publicly noticed, with comments, interventions, and protests due on or before February 18, 2022. Pursuant to Rule 214 (18 C.F.R. § 385.214 (2021)), to the extent that any timely filed motions to intervene and any motion to intervene out-of-time were filed before the issuance date of this order, such interventions are granted. Granting late interventions at this stage of the proceeding will not disrupt the proceeding or place additional burdens on existing parties. No protests or adverse comments were filed.

¹ PJM Interconnection, L.L.C., PJM Service Agreements Tariff, [PJM SA No. 6328, PJM SA # 6328 among PJM, Penn State Solar & West Penn Power \(0.0.0\)](#).

² See 18 C.F.R. 35.3(a)(2) (2021).

Docket No. ER22-919-000

- 2 -

This acceptance for filing shall not be construed as constituting approval of the referenced filing or of any rate, charge, classification, or any rule, regulation, or practice affecting such rate or service contained in your filing; nor shall such acceptance be deemed as recognition of any claimed contractual right or obligation associated therewith; and such acceptance is without prejudice to any findings or orders which have been or may hereafter be made by the Commission in any proceeding now pending or hereafter instituted by or against the applicant.

This order constitutes final agency action. Requests for rehearing by the Commission may be filed within 30 days of the date of issuance of this order, pursuant to 18 C.F.R. § 385.713 (2021).

Issued by: Kurt M. Longo, Director, Division of Electric Power Regulation – East

Document Content(s)

ER22-919-000 DLO.docx.....1



PJM Interconnection, L.L.C.
2750 Monroe Boulevard
Audubon, PA 19403

Christopher Holt
Assistant General Counsel
(610) 666-2368
Christopher.Holt@pjm.com

January 28, 2022

The Honorable Kimberly D. Bose
Secretary
Federal Energy Regulatory Commission
888 First Street, N.E., Room 1A
Washington, D.C. 20426

*Re: PJM Interconnection, L.L.C., Docket No. ER22-919-000
Original WMPA, SA No. 6328; Queue No. AG2-399*

Dear Secretary Bose:

Pursuant to section 205 of the Federal Power Act (“FPA”)¹ and part 35 of the regulations of the Federal Energy Regulatory Commission (“Commission”),² PJM Interconnection, L.L.C. (“PJM”) submits for filing a Wholesale Market Participation Agreement (“WMPA”) among PJM, Penn State Solar LLC (“Penn State Solar”) as Wholesale Market Participant, and West Penn Power Company (“West Penn Power”) as Transmission Owner, executed on January 19, 2022 (the “Penn State Solar WMPA”). PJM submits the Penn State Solar WMPA for filing because Wholesale Market Participant has requested interconnection of its generating facility to West Penn Power’s non-jurisdictional facilities for the purpose of engaging in Wholesale Transactions³ in the PJM markets. The WMPA, the appropriate agreement for the circumstances, is a form of agreement not presently contained in either the Tariff or any other PJM governing document. The WMPA applies only to Wholesale Transactions, and does not govern the actual physical interconnection

¹ 16 U.S.C. § 824d.

² 18 C.F.R. part 35.

³ Capitalized terms not defined herein have the meaning set forth in the PJM Open Access Transmission Tariff (“Tariff”).

of a generating facility to non-jurisdictional facilities. PJM requests waiver of the Commission's rules and regulations⁴ to permit an effective date of January 19, 2022 for the Penn State Solar WMPA, which is designated as Original Service Agreement No. 6328 and attached to this filing.⁵

I. BACKGROUND

A. *PJM's WMPA Process*

On February 22, 2006, the Commission issued an order⁶ which rejected two Interconnection Service Agreements filed by PJM on the basis that the interconnection of the underlying generators to non-jurisdictional distribution facilities was not, in and of itself, action regulated by the FPA.⁷ The Commission pointed out that in Order No. 2003,⁸ it determined that it does not have jurisdiction over an interconnection where an interconnection customer seeks to interconnect to a "local distribution" facility that is not used to provide transmission service under a Commission-approved open access transmission tariff at the time the interconnection request is submitted.⁹ The Commission also stated that in order to assert jurisdiction over such an interconnection, there must be a preexisting interconnection and a wholesale transaction over such facilities.¹⁰

⁴ 18 C.F.R. § 35.3(a)(2).

⁵ A copy of the Penn State Solar WMPA is included as Attachment A. Because the Penn State Solar WMPA being electronically filed with this transmittal letter contains electronic signatures and not the original signatures of the parties, a copy of the sheet containing the original signatures is included as Attachment B to this transmittal letter.

⁶ *PJM Interconnection, L.L.C.*, 114 FERC ¶ 61,191, at P 14 ("GSG Order I"), *order denying rehearing*, 116 FERC 61,116 (2006) ("GSG Order II", and with the GSG Order I, the "GSG Orders").

⁷ GSG Order I at PP 14-16; *see also* GSG Order II P 19 (denying rehearing and clarification and noting the FPA denies the Commission jurisdiction "over facilities used in local distribution").

⁸ *Standardization of Generator Interconnection Agreements and Procedures*, Order No. 2003, 104 FERC ¶ 61,103 (2003), *order on reh'g*, Order No. 2003-A, 106 FERC ¶ 61,220, *order on reh'g*, Order No. 2003-B, 109 FERC 61,287 (2004), *order on reh'g*, Order No. 2003-C, 111 FERC ¶ 61,401 (2005), *aff'd sub nom. Nat'l Ass'n of Regulatory Utils. Comm'rs v. FERC*, 475 F.3d 1277 (D.C. Cir. 2007), *cert. denied*, 552 U.S. 1230 (2008).

⁹ GSG Order I at P 14 (citing Order No. 2003 at P 804; Order No. 2003-C at P 53).

¹⁰ GSG Order I at P 14 (citing Order No. 2003 at P 804); *see also* Order No. 2003-A at P 710.

PJM routinely receives Interconnection Requests from generation developers seeking to interconnect at a distribution level in order to participate in sales to the PJM markets. These include requests to interconnect to distribution facilities that, consistent with the GSG Orders and Order No. 2003, are considered non-jurisdictional. In light of the GSG Orders and Order No. 2003, PJM developed the WMPA as a contractual means to address these requests and provide a process to properly track and study these distribution-level interconnections, and facilitate the generator's participation in PJM's organized wholesale markets. WMPAs also allow PJM to establish and set forth any necessary security and metering provisions. In instances when a non-jurisdictional interconnection could affect the integrated transmission system, the WMPA process allows PJM to ensure that this contingency is studied and corrected, if necessary.

PJM developed its first WMPAs in 2006 and filed those agreements pursuant to the Commission's jurisdiction under FPA section 205 and the Commission's independent jurisdictional authority over wholesale sales of electric energy and related products in PJM's markets.¹¹ The Commission accepted those filings and has routinely accepted the numerous WMPAs PJM has filed since then.¹² The instant filing is also being submitted pursuant to such jurisdiction and authority, and establishes the terms and conditions necessary to facilitate the Wholesale Market Participant's ability to make wholesale sales into PJM markets. PJM

¹¹ See *PJM Interconnection, L.L.C.*, Submission of Executed Wholesale Market Participation Agreement, Docket No. ER06-1343 (Aug. 4, 2006) (accepted in *PJM Interconnection, L.L.C.*, Letter Order, Wholesale Market Participation Agreement, Docket Nos. ER06-1343-000 and -001 (Dec. 27, 2006)); *PJM Interconnection, L.L.C.*, Submission of Executed Wholesale Market Participation Agreement, Docket No. ER06-1453-000 (Aug. 31, 2006) (accepted in *PJM Interconnection, L.L.C.*, Letter Order, Wholesale Market Participation Agreement, Docket Nos. ER06-1453-000, -001 and -002 (Mar. 9, 2007)); *PJM Interconnection, L.L.C.*, Submission of Executed Market Participation Agreement, Docket No. ER07-332-000 (Dec. 18, 2006) (accepted in *PJM Interconnection, L.L.C.*, Letter Order, Wholesale Market Participation Agreement, Docket No. ER07-332-000 (Jan. 31, 2007)).

¹² See, e.g., *PJM Interconnection, L.L.C.*, Letter Order, Wholesale Market Participant Agreement No. 5966, Docket No. ER21-1084-000 (Apr. 7, 2021); *PJM Interconnection, L.L.C.*, Letter Order, Wholesale Market Participation Agreement, Service Agreement No. 5855, Docket No. ER21-614-000 (Jan. 27, 2021); *PJM Interconnection, L.L.C.*, Letter Order, Original Service Agreement No. 5857, Docket No. ER21-535-000 (Jan. 25, 2021).

respectfully requests that Commission accept this WMPA, to be effective January 19, 2022, as requested.

B. Description of the Penn State Solar WMPA

The Penn State Solar WMPA facilitates participation by Wholesale Market Participant in PJM's organized wholesale markets, via wholesale sales from the 3 megawatt ("MW") Participant Facility located in Mercer Township, PA, in the West Penn Power Zone.¹³

The Penn State Solar WMPA provides that the Participant Facility shall be an Energy Resource, and Wholesale Market Participant will be permitted to sell energy into PJM's markets in an amount equal to the Participant Facility's Maximum Facility Output of 3 MW.¹⁴

Other provisions of the Penn State Solar WMPA establish general terms and conditions. These include effective date and termination provisions (section 1.1), notice provisions (section 2.0), and amendment and assignment provisions (sections 2.4. and 2.6). Section 3.0 indicates no security requirement. Section 3.1.4 specifies that Penn State Solar must enter into a two-party Interconnection Agreement with West Penn Power on or before September 30, 2022 to effectuate the Penn State Solar WMPA. The Schedules to the Penn State Solar WMPA include a Single-Line Diagram (Schedule A), List of Metering Equipment (Schedule B), and Wholesale Market Participant's Agreement to Conform with IRS Safe Harbor Provisions for Non-Taxable Status (Schedule E). Schedules C (List of Local/Network Upgrades), D (Applicable Technical Requirements and Standards), and F (Schedule of Non-Standard Terms & Conditions) are not

¹³ See Penn State Solar WMPA, Specifications, section 1.0.

¹⁴ *Id.*, Specifications, section 2.0; *see supra* n. 12 (accepting WMPAs granting similar Energy Resource rights).

required. Each of these general terms and conditions is consistent with those contained in other WMPAs accepted by the Commission.¹⁵

II. WAIVER AND EFFECTIVE DATE

PJM requests that the Commission grant any and all waivers of the Commission's rules and regulations that are necessary for acceptance of this filing and the enclosed Penn State Solar WMPA. Consistent with the Commission's notice requirements for service agreements, 18 C.F.R. § 35.3(a)(2), PJM requests that the Commission grant an effective date for the Penn State Solar WMPA of January 19, 2022, as this filing is being submitted within 30 days of the requested effective date.

To the extent necessary, PJM also requests waiver of the Commission's 60-day prior notice requirement, 18 C.F.R. § 35.3(a)(1), to allow this effective date. Waiver is appropriate because this effective date is consistent with the intent of the parties, as set forth in section 1.1 of the Penn State Solar WMPA. Further, the requested waiver is limited in scope and will result in no harm to third parties. The Commission has allowed waivers of its prior notice requirements when the filing is uncontested and does not change rates,¹⁶ and for other filings involving WMPAs.¹⁷

III. DOCUMENTS ENCLOSED

In addition to this transmittal letter, PJM encloses the following:

(1) Attachment A: Original WMPA - Service Agreement No. 6328 (Clean Format); and

¹⁵ See *supra* n. 12.

¹⁶ See *ISO New England Inc.*, 116 FERC ¶ 61,308, at P 8 (2006); see also *Cent. Hudson Gas & Elec. Corp.*, 60 FERC 61,106, at 61,338 (1992) (waiving prior notice requirement when uncontested filings do not change rates).

¹⁷ See *supra* n. 12. If the Commission does not allow an effective date of January 19, 2022, PJM requests that the Commission grant the earliest effective date possible, and no later than January 29, 2022, one day after this filing. The Commission has allowed jurisdictional agreements to become effective one day after filing. See *Palo Duro Wind Interconnection Servs., LLC*, 149 FERC ¶ 61,205, at P 9 (2014); *Midcontinent Indep. Sys. Operator, Inc.*, 145 FERC 61,032, at P 49 (2013).

(2) Attachment B: Original WMPA - Service Agreement No. 6328, Copy of Original Signature Page.

IV. SERVICE

Copies of this filing have been served upon Wholesale Market Participant, Transmission Owner, and the affected state utility commissions within the PJM region.

V. CORRESPONDENCE AND COMMUNICATIONS

All notices, communications, or correspondence addressed to PJM regarding this matter should be directed to, and PJM requests that the Secretary include on the Commission's official service list, the following:¹⁸

Craig Glazer
Vice President – Federal Government Policy
PJM Interconnection, L.L.C.
1200 G Street, NW, Suite 600
Washington, DC 20005
(202) 423-4743
Craig.Glazer@pjm.com

Christopher B. Holt
Assistant General Counsel
PJM Interconnection, L.L.C.
2750 Monroe Blvd,
Audubon, PA 19403
610-666-2368
Christopher.Holt@pjm.com

¹⁸ To the extent necessary, PJM requests waiver of Rule 203(b)(3) of the Commission's Rules of Practice and Procedure, 18 C.F.R. § 385.203(b)(3), to permit all of the persons listed to be placed on the official service list for this proceeding.

VI. CONCLUSION

For the foregoing reasons, PJM requests that the Commission accept the Penn State Solar WMPA with an effective date of January 19, 2022.

Respectfully submitted,

By: /s/Christopher Holt

Craig Glazer
Vice President–Federal Government Policy
PJM Interconnection, L.L.C.
1200 G Street, N.W, Suite 600
Washington, D.C. 20005
(202) 423-4743
Craig.Glazer@pjm.com

Christopher Holt
Assistant General Counsel
PJM Interconnection, L.L.C.
2750 Monroe Blvd
Audubon, PA 19403-2497
(610) 666-2368
Christopher.Holt@pjm.com

Cc via email only: Wholesale Market Participant
Eileen Turano – eileen.turano@saturnpower.com

Transmission Owner
Mike Thorn – mthorn@firstenergycorp.com
Amanda Parker – aparker@firstenergycorp.com
Tricia Hartzell – thartzell@firstenergycorp.com

All state utility regulatory commissions within the PJM region

ATTACHMENT A

**Original WMPA, Service Agreement No. 6328
(Clean Format)**

(PJM Queue #AG2-399)

WHOLESALE MARKET PARTICIPATION AGREEMENT
Among
PJM INTERCONNECTION, L.L.C.
And
PENN STATE SOLAR LLC
And
WEST PENN POWER COMPANY

WHOLESALE MARKET PARTICIPATION AGREEMENT

**By and Among
PJM Interconnection, L.L.C.
And
Penn State Solar LLC
And
West Penn Power Company
(PJM Queue Position #AG2-399)**

This Wholesale Market Participation Agreement (“WMPA”) including the Specifications, and Schedules attached hereto and incorporated herein, is entered into in order to effectuate sales of energy and/or capacity into PJM’s wholesale markets, by and between PJM Interconnection, L.L.C., the Regional Transmission Organization for the PJM Region (“Transmission Provider”), Penn State Solar LLC (“Wholesale Market Participant”) and West Penn Power Company (“Transmission Owner” or “WPP”) (referred to individually as “Party” or collectively as “the Parties”).

WITNESSETH

WHEREAS, Wholesale Market Participant is developing generation that it intends to use to engage in Wholesale Transactions in PJM’s markets and desires to maintain its proposed generation in the queue that PJM studies for potential reliability impacts to the Transmission System;

WHEREAS, Wholesale Market Participant is seeking to interconnect at a local distribution or sub-transmission facility, which at this time is not subject to FERC jurisdiction; and

WHEREAS, Wholesale Market Participant and Transmission Owner or its affiliate must enter into a separate two-party interconnection agreement (“Interconnection Agreement”) in order to address issues of physical interconnection and local charges that may be presented by the interconnection of Wholesale Market Participant’s generation to the distribution facility.

NOW, THEREFORE, in consideration of the mutual covenants herein contained, together with other good and valuable consideration, the receipt and sufficiency is hereby mutually acknowledged by Transmission Provider, Transmission Owner and Wholesale Market Participant and the parties agree to assume all of the rights and obligations consistent with the rights and obligations relating to Network Upgrades, Local Upgrades and metering requirements set forth in Part VI of the Tariff, as of the effective date of this WMPA, required for Wholesale Market Participant to make Wholesale Transactions in PJM’s markets. The Parties mutually covenant and agree as follows:

Article 1 – DEFINITIONS and OTHER DOCUMENTS

- 1.0 Defined Terms.** All capitalized terms herein shall have the meanings as set forth in the definitions of such terms as stated in Part I, Article 1 or Part VI of the PJM Open Access Transmission Tariff (“Tariff”), except Wholesale Market Participant which shall be defined in this WMPA as a participant in a Wholesale Transaction.
- 1.1 Effective Date.** This WMPA shall become effective on the date it is executed by all Parties, or, if this WMPA is filed with FERC unexecuted, upon the date specified by FERC. This WMPA shall terminate on such date as mutually agreed upon by the parties, unless earlier terminated consistent with Section 1 in Attachment O, Appendix 2, Part VI of the Tariff.
- 1.2 Assumption of Tariff Obligations.** Wholesale Market Participant agrees to abide by all rules and procedures pertaining to generation and transmission in the PJM Region, including but not limited to the rules and procedures concerning the dispatch of generation or scheduling transmission set forth in the Tariff, the Operating Agreement and the PJM Manuals.
- 1.3 Incorporation Of Other Documents.** All portions of the Tariff and the Operating Agreement pertinent to the subject matter of this WMPA and not otherwise made a part hereof are hereby incorporated herein and made a part hereof.

Article 2 - NOTICES and MISCELLANEOUS

- 2.0 Notices.** Any notice, demand or request required or permitted to be given by any Party to another and any instrument required or permitted to be tendered or delivered by any Party in writing to another may be so given, tendered or delivered by recognized national courier or by depositing the same with the United States Postal Service, with postage prepaid for delivery by certified or registered mail addressed to the Party, or by personal delivery to the Party, at the address specified below. Such notices, if agreed to by the Parties, may be made via electronic means, with e-mail confirmation of delivery.

Transmission Provider:

PJM Interconnection, L.L.C.
2750 Monroe Blvd.
Audubon, PA 19403-2497

Wholesale Market Participant:

Penn State Solar LLC
140 Foundry Street
Baden, ON N3A2P7

Attn: Eileen Turano
eileen.turano@saturnpower.com
519-497-6864
Transmission Owner:

West Penn Power Company
76 South Main Street
A-GO-10
Akron, OH 44308
Attn: Mike Thorn, FERC & Wholesale Connection Support Manager
mthorn@firstenergycorp.com
(330) 384-3889

Amanda Parker – Interconnections Attorney
FirstEnergy Service Company
76 South Main Street
A-GO-15
Akron, OH 44308
aparker@firstenergycorp.com

Tricia Hartzell-Legal Specialist
FirstEnergy Service Company
76 South Main Street
A-GO-15
Akron, OH 44308
thartzell@firstenergycorp.com
(330) 761-4426

With copies to:
FirstEnergy Service Company
Legal Department
76 South Main Street
A-GO-15
Akron, OH 44308
Attn: Attorney for FERC & Wholesale Connection Support

Either Party may change its address or designated representative for notice by notice to the other Parties in the manner provided for above.

- 2.1 Construction With Other Parts Of The Tariff.** This WMPA shall not be construed as an application for service under Part II or Part III of the Tariff.
- 2.2 Warranty for Facilities Study.** In analyzing and preparing the System Impact Study, and in designing and constructing the Local Upgrades and/or Network Upgrades described in Part II of the Tariff and in the Specifications attached to this WMPA, Transmission Provider, the Transmission Owner(s), and any other subcontractors

employed by Transmission Provider have had to, and shall have to, rely on information provided by Wholesale Market Participant and possibly by third parties and may not have control over the accuracy of such information. Accordingly, NEITHER TRANSMISSION PROVIDER, THE TRANSMISSION OWNER(s), NOR ANY OTHER SUBCONTRACTORS EMPLOYED BY TRANSMISSION PROVIDER OR TRANSMISSION OWNER MAKES ANY WARRANTIES, EXPRESS OR IMPLIED, WHETHER ARISING BY OPERATION OF LAW, COURSE OF PERFORMANCE OR DEALING, CUSTOM, USAGE IN THE TRADE OR PROFESSION, OR OTHERWISE, INCLUDING WITHOUT LIMITATION IMPLIED WARRANTIES OF MERCHANTABILITY AND FITNESS FOR A PARTICULAR PURPOSE, WITH REGARD TO THE ACCURACY, CONTENT, OR CONCLUSIONS OF THE FACILITIES STUDY OR THE SYSTEM IMPACT STUDY IF A FACILITIES STUDY WAS NOT REQUIRED OR OF THE LOCAL UPGRADES AND/OR THE NETWORK UPGRADES. Wholesale Market Participant acknowledges that it has not relied on any representations or warranties not specifically set forth herein and that no such representations or warranties have formed the basis of its bargain hereunder.

2.3 Waiver. No waiver by any party of one or more defaults by the other in performance of any of the provisions of this WMPA shall operate or be construed as a waiver of any other or further default or defaults, whether of a like or different character.

2.4 Amendment. This WMPA or any part thereof, may not be amended, modified, or waived other than by a written document signed by all parties hereto.

2.5 Addendum of Wholesale Market Participant's Agreement to Conform with IRS Safe Harbor Provisions for Non-Taxable Status. To the extent required, in accordance with Section 24.1 in Attachment O, Appendix 2 in Part VI of the Tariff, Schedule E to this WMPA shall set forth the Wholesale Market Participant's agreement to conform with the IRS safe harbor provisions for non-taxable status.

2.6 Assignment

2.6.1 Assignment with Prior Consent:

If the Interconnection Agreement between the Wholesale Market Participant and the Transmission Owner, as referenced in section 3.1.4 herein, provides that such Interconnection Agreement may be assigned, and such Interconnection Agreement was assigned, then, except as provided in Section 2.6.2 of this WMPA, no Party shall assign its rights or delegate its duties under this WMPA without the prior written consent of the other Parties, which consent shall not be unreasonably withheld, conditioned, or delayed; and any such assignment or delegation made without such prior written consent shall be null and void. A Party may make an assignment in connection with the sale, merger, or transfer of all of its properties, including the Participant Facility, which it owns, so long as the assignee in such a sale, merger, or transfer assumes in writing all rights, duties and obligations arising under this WMPA. In addition, the Transmission Owner shall be entitled, subject to applicable laws and regulations, to assign the WMPA to an Affiliate or

successor that owns and operates all or a substantial portion of the Transmission Owner's transmission facilities.

2.6.2 Assignment without Prior Consent

2.6.2.1 Assignment to Owners:

If the Interconnection Agreement between the Wholesale Market Participant and the Transmission Owner, as referenced in section 3.1.4 herein, provides that such Interconnection Agreement may be assigned, and such Interconnection Agreement was assigned, then the Wholesale Market Participant may assign its rights or delegate its duties under this WMPA without the Transmission Owner's or Transmission Provider's prior consent to any Affiliate or person that purchases or otherwise acquires, directly or indirectly, all of the Participant Facility, provided that prior to the effective date of any such assignment: (1) the assignee shall demonstrate that, as of the effective date of the assignment, the assignee has the technical and operational competence to comply with the requirements of this WMPA; and (2) in writing to the Transmission Owner and Transmission Provider, assignee assumes all rights, duties, and obligations of Wholesale Market Participant arising under this WMPA. However, any assignment described herein shall not relieve or discharge the Wholesale Market Participant from any of its obligations hereunder absent the written consent of the Transmission Provider, such consent not to be unreasonably withheld, conditioned or delayed.

2.6.2.2 Assignment to Lenders:

If the Interconnection Agreement between the Wholesale Market Participant and the Transmission Owner, as referenced in section 3.1.4 herein, provides that such Interconnection Agreement may be assigned to any Project Finance Entity(ies), and such Interconnection Agreement was assigned, then the Wholesale Market Participant may, without consent of the Transmission Provider or the Transmission Owner, assign this WMPA to such Project Finance Entity(ies), provided that such assignment does not alter or diminish Wholesale Market Participant's duties and obligations under this WMPA. If Wholesale Market Participant provides the Transmission Owner and Transmission Provider with notice of an assignment to such Project Finance Entity(ies) and identifies such Project Finance Entity(ies) as a contact for notice of Breach consistent with section 15.3 of Attachment O, Appendix 2 in Part VI of the Tariff, the Transmission Provider or Transmission Owner shall provide notice and reasonable opportunity for such Project Finance Entity(ies) to cure any Breach under this WMPA in accordance with this WMPA. Transmission Provider or Transmission Owner shall, if requested by such Project Finance Entity(ies), provide such customary and reasonable documents, including consents to assignment, as may be reasonably requested with respect to the assignment and status of this WMPA, provided that such documents do not alter or diminish the rights of the Transmission Provider or Transmission Owner under this WMPA,

except with respect to providing notice of Breach consistent with section 15.3 of Attachment O, Appendix 2 in Part VI of the Tariff, to such Project Finance Entity(ies). Upon presentation of the Transmission Provider and/or Transmission Owner's invoice therefor, Wholesale Market Participant shall pay the Transmission Provider and/or the Transmission Owner's reasonable documented cost of providing such documents and certificates as requested by such Project Finance Entity(ies). Any assignment described herein shall not relieve or discharge the Wholesale Market Participant from any of its obligations hereunder absent the written consent of the Transmission Owner and Transmission Provider.

2.6.3 Successors and Assigns:

This WMPA and all of its provisions are binding upon, and inure to the benefit of, the Parties and their respective successors and permitted assigns.

ARTICLE 3 – Responsibility for Network or Local Upgrades

- 3.0 Security for Network or Local Upgrades.** Consistent with Section 212.4 in Part VI of the Tariff, Wholesale Market Participant, on or before the effective date of this WMPA, shall provide the Transmission Provider (for the benefit of the Transmission Owner) with a letter of credit from an agreed provider or other form of security reasonably acceptable to the Transmission Provider and that names the Transmission Provider as beneficiary (“Security”) in the amount of \$0. This amount represents the sum of the estimated Costs, determined consistent with Section 217 in Part VI of the Tariff, of (i) the Local Upgrades and/or Network Upgrades less any Costs already paid by the Wholesale Market Participant. Should Wholesale Market Participant fail to provide Security in the amount or form required in the first sentence of this Section, this WMPA shall be terminated. Wholesale Market Participant acknowledges that its ultimate cost responsibility consistent with Section 217 in Part VI of the Tariff will be based upon the actual Costs of the facilities described in the Specifications to this WMPA, whether greater or lesser than the amount of the Security provided under this Section.
- 3.1 Project Specific Milestones.** During the term of this WMPA, Wholesale Market Participant shall ensure that it meets each of the following milestones:
- 3.1.1 Substantial Site work completed.** On or before September 30, 2023 Wholesale Market Participant must demonstrate completion of at least 20% of project site construction.
- 3.1.2 Commercial Operation.** (i) On or before December 31, 2023, Wholesale Market Participant must demonstrate commercial operation of all generating units; (ii) On or before December 31, 2023, Wholesale Market Participant must demonstrate commercial sale or use of energy and, if applicable obtain capacity qualification consistent with the requirements of the Reliability Assurance Agreement Among Load Serving Entities in the PJM Region.
- 3.1.3 Documentation.** Within one (1) month following commercial operation of generating unit(s), Wholesale Market Participant must provide certified documentation demonstrating that “as-built” Participant Facility are consistent with applicable PJM studies and agreements. Wholesale Market Participant must also provide PJM with “as-built” electrical modeling data or confirm that previously submitted data remains valid.
- 3.1.4 Interconnection Agreement.** On or before September 30, 2022, Wholesale Market Participant must enter into an Interconnection Agreement with the in order to effectuate the WMPA. This WMPA shall automatically terminate upon the termination of the two-party Interconnection Agreement between the Wholesale Market Participant and Transmission Owner.

Wholesale Market Participant shall demonstrate the occurrence of each of the foregoing milestones to Transmission Provider's reasonable satisfaction. Transmission Provider may reasonably extend any such milestone dates, in the event of delays that Wholesale Market Participant (i) did not cause and (ii) could not have remedied through the exercise of due diligence.

If (i) the Wholesale Market Participant suspends work pursuant to a suspension provision contained in an interconnection and/or construction agreement with the Transmission Owner or (ii) the Transmission Owner extends the date by which Wholesale Market Participant must enter into an interconnection agreement relative to this WMPA, and (iii) the Wholesale Market Participant has not made a wholesale sale under this WMPA, the Wholesale Market Participant may suspend this WMPA by notifying the Transmission Provider and the Transmission Owner in writing that it wishes to suspend this WMPA, with the condition that, notwithstanding such suspension, the Transmission System shall be left in a safe and reliable condition in accordance with Good Utility Practice and Transmission Provider's safety and reliability criteria. Wholesale Market Participant's notice of suspension shall include an estimated duration of the suspension period and other information related to the suspension. Pursuant to this section 3.1, Wholesale Market Participant may request one or more suspensions of work under this WMPA for a cumulative period of up to a maximum of three years. If, however, the suspension will result in a Material Modification as defined in Part I, Section 1.18A.02 of the Tariff, then such suspension period shall be no greater than one (1) year. If the Wholesale Market Participant suspends this WMPA pursuant to this Section 3.1 and has not provided written notice that it will exit such suspension on or before the expiration of the suspension period described herein, this WMPA shall be deemed terminated as of the end of such suspension period. The suspension time shall begin on the date the suspension is requested or on the date of the Wholesale Market Participant's written notice of suspension to Transmission Provider, if no effective date was specified. All milestone dates stated in this Section 3.1 shall be deemed to be extended coextensively with any suspension period permitted pursuant to this provision.

IN WITNESS WHEREOF, Transmission Provider, Wholesale Market Participant and Transmission Owner have caused this WMPA to be executed by their respective authorized officials. By each individual signing below, each represents to the other that they are duly authorized to sign on behalf of their company and have the actual and/or apparent authority to bind the respective company to this WMPA.

(PJM Queue Position #AG2-399)

Transmission Provider: **PJM Interconnection, L.L.C.**

By: <u>/s/ Jason Shoemaker</u>	<u>Manager, Interconnection Projects</u>	<u>1/19/2022</u>
Name	Title	Date

Printed name of signer: Jason Shoemaker

Wholesale Market Participant: **Penn State Solar LLC**

By: <u>/s/ Ray Roth</u>	<u>COO</u>	<u>1/7/2022</u>
Name	Title	Date

Printed name of signer: Ray Roth

Transmission Owner: **West Penn Power Company**

By: <u>/s/ Greg Hussing</u>	<u>Dir FERC & RTO Support</u>	<u>1/17/2022</u>
Name	Title	Date

Printed name of signer: Greg Hussing

**SPECIFICATIONS FOR
WHOLESALE MARKET PARTICIPATION AGREEMENT**

**By and Among
PJM INTERCONNECTION, L.L.C.**

And

Penn State Solar LLC

And

**West Penn Power Company
(PJM Queue Position # AG2-399)**

1.0 Description of generating unit(s) (the “Participant Facility” or “Participant’s Facility”) to be used for the provision of wholesale sales into the PJM markets:

a. Name of Participant Facility:

Eau Claire Solar

b. Location of Participant Facility:

GPS Coordinates: 41.1434890, -79.9873180
West Penn Power Zone

c. Size in megawatts of Participant Facility:

Maximum Facility Output of 3 MW

d. Description of the equipment configuration:

A ground-mounted, inverter-based, solar photovoltaic generating facility consisting of solar arrays, a collection system, and step-up transformation with a high-side voltage of 25 kV.

2.0 Rights for Generation Wholesale Market Participant

2.1 Energy Resource: The Participant Facility described in Section 1.0 shall be an Energy Resource. Pursuant to this WMPA, the Wholesale Market Participant may sell energy into PJM’s markets in an amount equal to the Participant Facility’s Maximum Facility Output indicated in Section 1.0c of the Specifications for this WMPA. PJM reserves the right to limit injections in the event reliability would be affected by output greater than such quantity.

3.0 Ownership and Location of Metering Equipment. The metering equipment to be constructed, the capability of the metering equipment to be constructed, and the ownership

thereof, as required for the Wholesale Transactions shall be identified on the attached Schedule B to this WMPA, and provided consistent with the PJM manuals.

SCHEDULES:

- **SCHEDULE A - SINGLE-LINE DIAGRAM (Showing point of interconnection)**
- **SCHEDULE B - LIST OF METERING EQUIPMENT**
- **SCHEDULE C - LIST OF LOCAL/NETWORK UPGRADES**
- **SCHEDULE D - APPLICABLE TECHNICAL REQUIREMENTS AND STANDARDS**
- **SCHEDULE E - WHOLESALE MARKET PARTICIPANT AGREEMENT TO CONFORM WITH IRS SAFE HARBOR PROVISIONS FOR NON-TAXABLE STATUS**
- **SCHEDULE F – SCHEDULE OF NON-STANDARD TERMS & CONDITIONS**

SCHEDULE A
SINGLE-LINE DIAGRAM

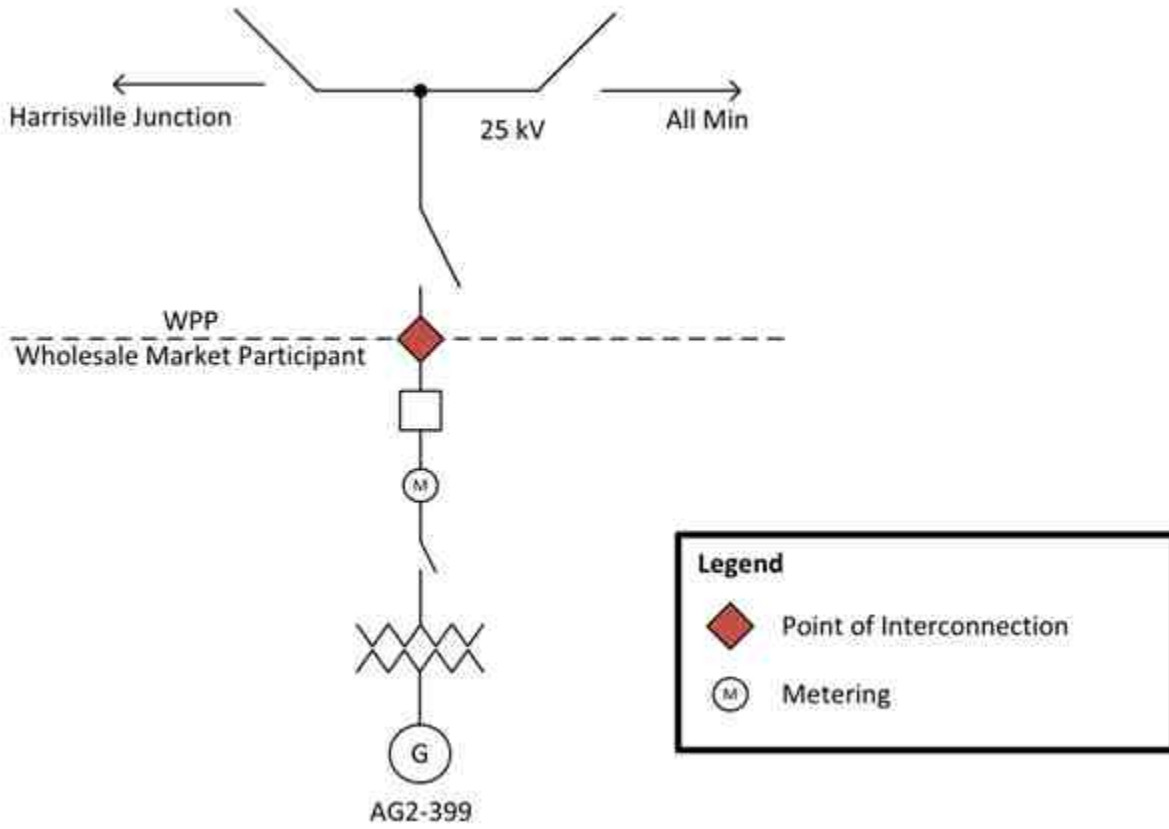

SCHEDULE B

LIST OF METERING EQUIPMENT

Wholesale Market Participant is responsible for installing metering & telemetry equipment that shall comply with requirements specified in PJM Manuals M-01 and M-14D.

SCHEDULE C

LIST OF LOCAL/NETWORK UPGRADES

Not Required.

SCHEDULE D

APPLICABLE TECHNICAL REQUIREMENTS AND STANDARDS

Not Required.

SCHEDULE E

WHOLESALE MARKET PARTICIPANT'S AGREEMENT TO CONFORM WITH IRS SAFE HARBOR PROVISIONS FOR NON-TAXABLE STATUS

As provided in Section 24.1 in Attachment O, Appendix 2 in Part VI of the Tariff and subject to the requirements thereof, Wholesale Market Participant represents that it meets all qualifications and requirements as set forth in Section 118(a) and 118(b) of the Internal Revenue Code of 1986, as amended and interpreted by Notice 2016-36, 2016-25 I.R.B. (6/20/2016) (the "IRS Notice"). Wholesale Market Participant agrees to conform with all requirements of the safe harbor provisions specified in the IRS Notice, as they may be amended, as required to confer non-taxable status on some or all of the transfer of property, including money, by Wholesale Market Participant to Transmission Owner with respect to the payment of the Costs of construction and installation of the Transmission Owner Interconnection Facilities specified in this WMPA.

Nothing in Wholesale Market Participant's agreement pursuant to this Schedule E shall change the indemnification obligations under Section 24.2 in Attachment O, Appendix 2 in Part VI of the Tariff.

SCHEDULE F

SCHEDULE OF NON-STANDARD TERMS & CONDITIONS

Not Required.

ATTACHMENT B

**Original WMPA, Service Agreement No. 6328
Copy of Original Signature Page**

IN WITNESS WHEREOF, Transmission Provider, Wholesale Market Participant and Transmission Owner have caused this WMPA to be executed by their respective authorized officials. By each individual signing below, each represents to the other that they are duly authorized to sign on behalf of their company and have the actual and/or apparent authority to bind the respective company to this WMPA.

(PJM Queue Position #AG2-399)

Transmission Provider: **PJM Interconnection, L.L.C.**

By: Jason Shoemaker Manager, Interconnection Projects 1/19/2022
Name Title Date

Printed name of signer: Jason Shoemaker

Wholesale Market Participant: **Penn State Solar LLC**

By: Ray Roth COO 1/7/2022
Name Title Date

Printed name of signer: Ray Roth

Transmission Owner: **West Penn Power Company**

By: Greg Husing Dir FERC & RTO Support 1/17/2022
Name Title Date

Printed name of signer: Greg Husing